



GUZZLER® 115 VAC DIAPHRAGM PUMPS



OPERATOR'S MANUAL FOR ...

GE-0401D

GE-0401N

GE-0501D

GE-0501N

for **use as Maple Sap Vacuum** pumps

WWW.THEBOSWORTHCO.COM

Guzzler GE-0401x Pump Exploded View

Item #	Part Name
1	Inlet Flange
2	Outlet Flange
3B	Bottom Button & Stainless Steel Washer
4	Clevis
4B	Connecting Rod with Bearing
5	Body
6B	Intermediate Ring
7C	Motor Mounting Plate
12	Miscellaneous Hardware (10-24 Screws & Nuts)
12C	TH1/4-20x1/2 (1) Diaphragm Screw
13	Diaphragm
14	Flapper Valves
15	Umbrella Valves (Umbrella valves (2), Valve Stops (2), O-rings (4), Screws & Nuts)
16	Duckbill Valves
18C	Connecting Rod Bolt w/Spacer
19A	Crank Arm (18 mm) with 1/4-20 Set Screws (2)
19B	Crank Arm (5/8 in) with 1/4-20 Set Screws (2)
20	Motor Mounting Bracket
21	GearMotor
22	Switch Box w/Toggle Switch, Capacitor, motor cord and connectors
23	Pump Guard
PS-GE	Pin set for GE pumps

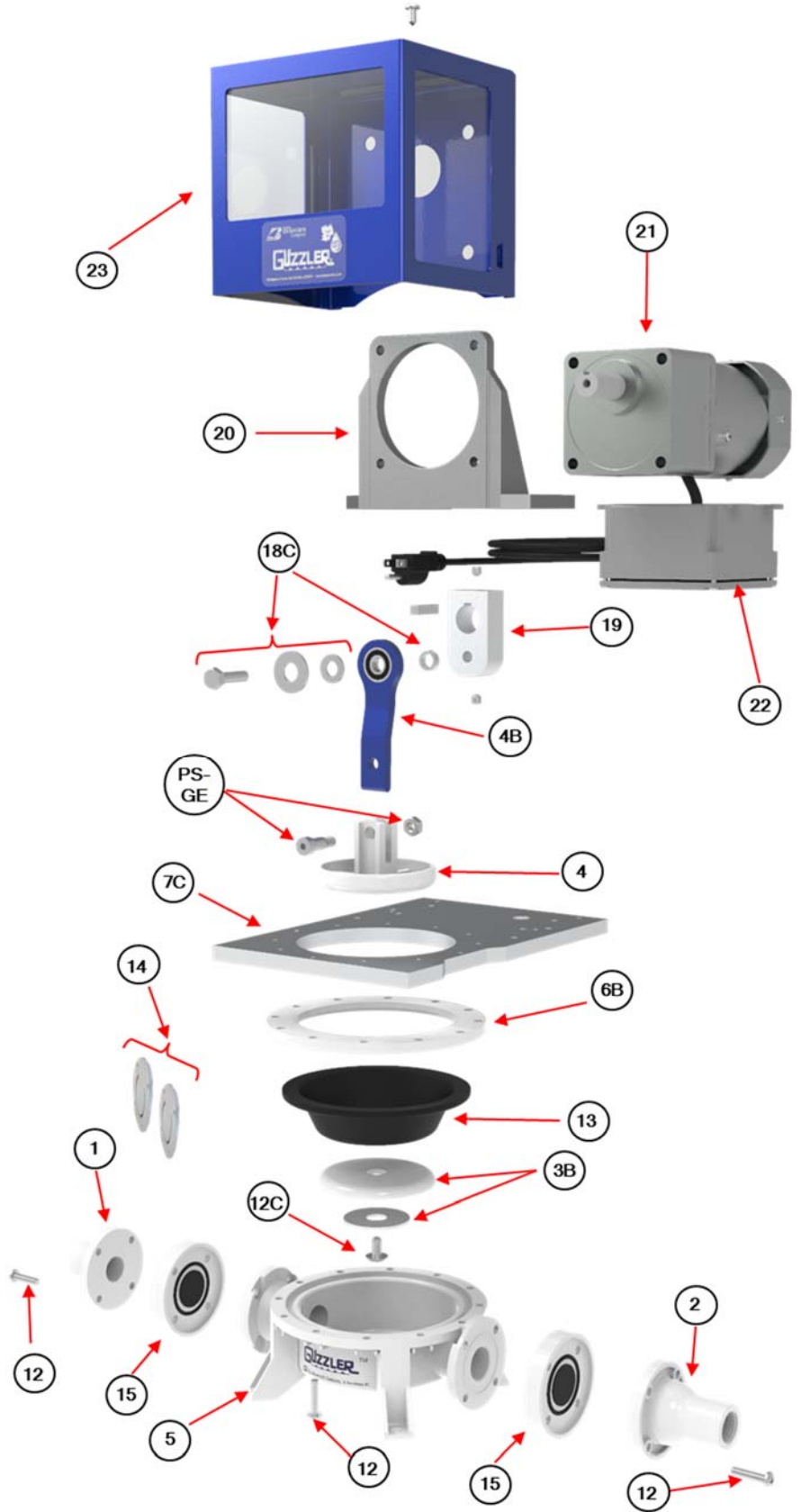

Note:

GE-0401N is pictured.
 GE-0401D has gray body, flanges, buttons and intermediate ring.

Guzzler GE-0501x Pump - Exploded View

Item #	Part Name
1	Inlet Flange
2	Outlet Flange
3B	Bottom Button & Stainless Steel Washer
4	Clevis
4B	Connecting Rod with Bearing
5	Body
6B	Intermediate Ring
7C	Motor Mounting Plate
12	Miscellaneous Hardware (10-24 Screws & Nuts)
12C	TH1/4-20x1/2 (1) Diaphragm Screw
13	Diaphragm
14	Flapper Valves
15	Umbrella Valves (Umbrella valves (2), Valve Stops (2), O-rings (4), Screws & Nuts)
16	Duckbill Valves
18C	Connecting Rod Bolt & Spacer
19A	Crank Arm (18 mm) with 1/4-20 Set Screws (2)
19B	Crank Arm (5/8 in) with 1/4-20 Set Screws (2)
20	Motor Mounting Bracket
21	GearMotor
22	Switch Box w/Toggle Switch, Capacitor, motor cord and connectors
23	Pump Guard
PS-GE	Pin set for GE pumps

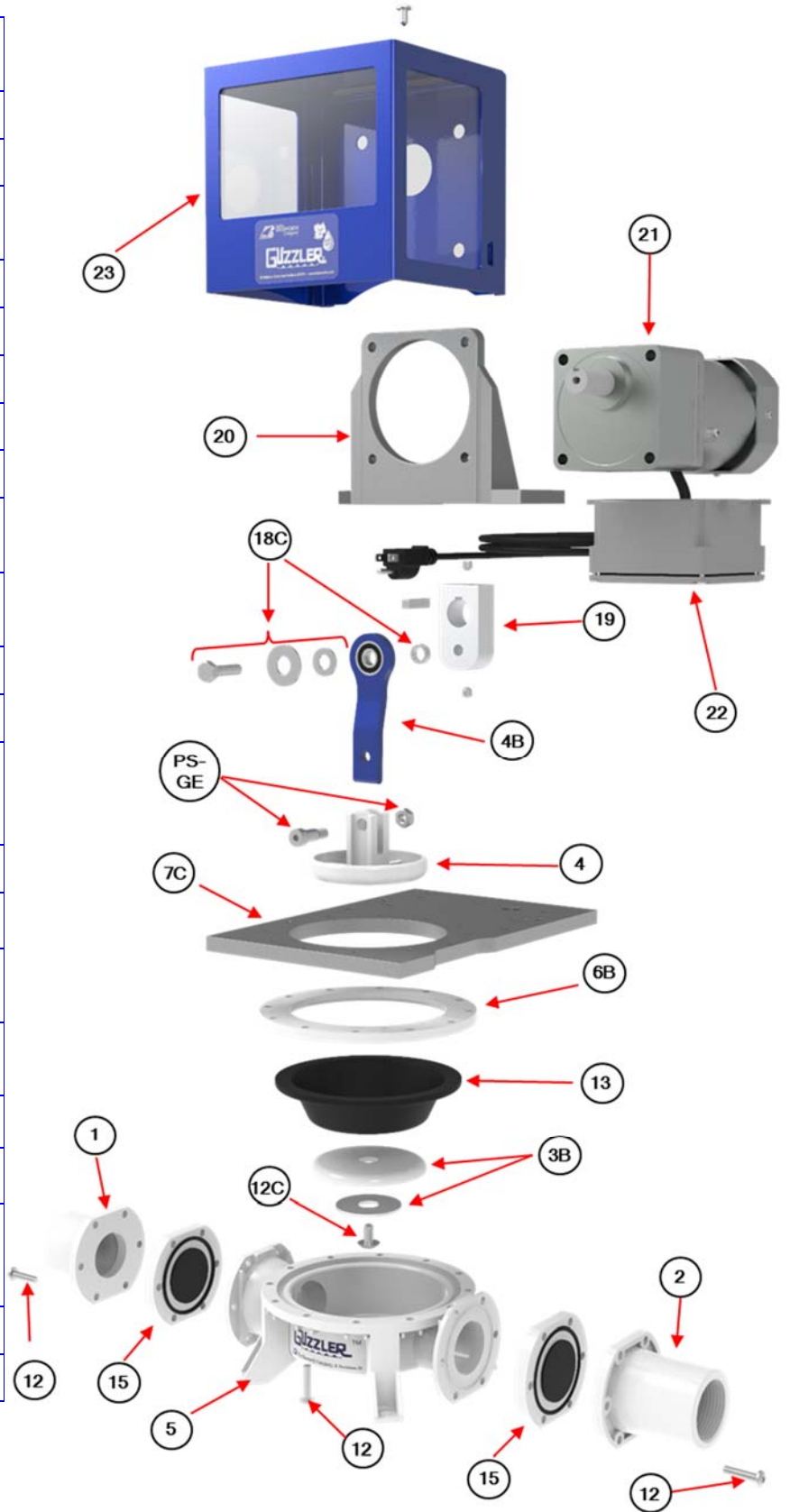

Note:

GE-0501N is pictured
 GE-0501D has gray body, flanges, buttons and intermediate ring.

Guzzler GE-0401x / -0501x Pump Installation & Safety Information

Your Guzzler pump ships fully assembled and ready to operate. The pump on/off switch is located on the side of the switch box. (Figure 1)

You can test the pump's operation by plugging it into a 115 VAC outlet and turning it on using the on/off switch. Carefully place your hand over the inlet port (the shorter of the two pump ports) of the pump. You will feel the pump sucking your hand toward the port. Take your hand away and now place it over the outlet port of the pump. You will feel the pump's exhaust pushing your hand away from the port. When you can feel the vacuum created at the inlet port and the positive exhaust pressure generated at the outlet port, the pump is operating properly.

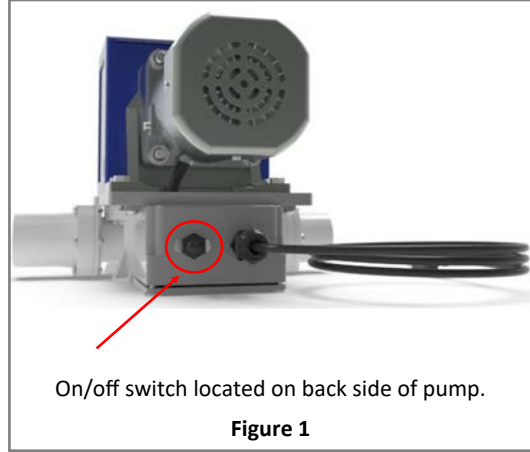

The Guzzler should be securely mounted to a mounting surface prior to operation. The four pump feet have mounting holes that can accommodate a 1/4 in (6.4 mm) diameter bolt or screw. The holes are arranged on a square, 4-5/16 in (109.5 mm) on a side, inscribed on a bolt circle of diameter 6-1/8 in (155.6 mm). (Figure 2) We recommend countersinking holes on the bottom of a mounting surface and inserting mounting bolts up through those holes and through the pump feet. Secure the end of the bolt with a nut.

Your Guzzler pump has a range of different inlet and outlet ports available to accommodate a range of different connections to your sap lines and collection tank tubing. We recommend the use of Quick Connect Couplers so that the pump can be easily disconnected from and reconnected to your lines.

The pump should be protected from the weather. If it is placed in an enclosure, be sure to allow adequate airflow around the motor for cooling.

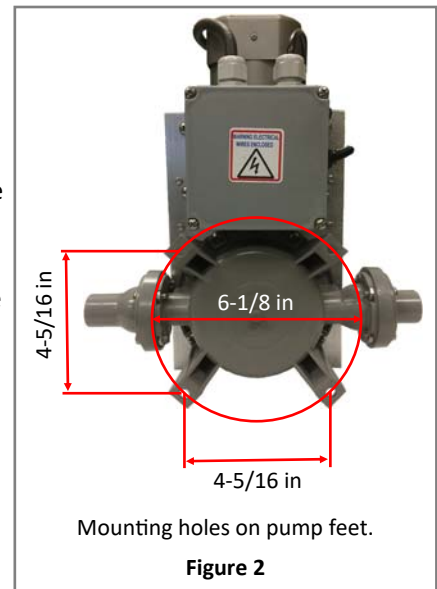

Your Guzzler pump requires 115 VAC power. If power is not readily available, it can be provided from a generator that supports a minimum 200 running watt output. (The motor is rated for 1.44 amps at full load.) Be sure that the generator is actually delivering 115 VAC, as deviations from this voltage – lower or higher – will result in improper motor operation.

IMPORTANT SAFETY INFORMATION

NEVER OPERATE YOUR GUZZLER PUMP WITHOUT THE PUMP GUARD PROPERLY INSTALLED ON THE PUMP.

NEVER REACH INSIDE THE PUMP OR INSERT ANY OBJECTS INTO THE PUMP WHILE THE PUMP IS OPERATING. SERIOUS INJURY OR DAMAGE TO THE PUMP WILL RESULT.

ALWAYS CONNECT THE PUMP TO A PROPERLY GROUNDED CIRCUIT. OPERATING THE PUMP WITHOUT CONNECTION TO A PROPERLY GROUNDED CIRCUIT CAN CREATE A SERIOUS RISK OF ELECTRICAL SHOCK.

Pump Installation and Operating Information

Your Guzzler Pump is capable of developing 22 in. of Hg vacuum (0.7 bar), but it is a low-cfm (cubic feet of air per minute) pump. This means that even very small leaks can prevent the pump from delivering its rated vacuum. Maintain your tap lines to keep your system tight and address problems that can cause vacuum leaks.

It is best to install your Guzzler at or above collection tank level to avoid shortening diaphragm life. This will reduce the output pressure on the diaphragm, thus reducing mechanical stress on the diaphragm.

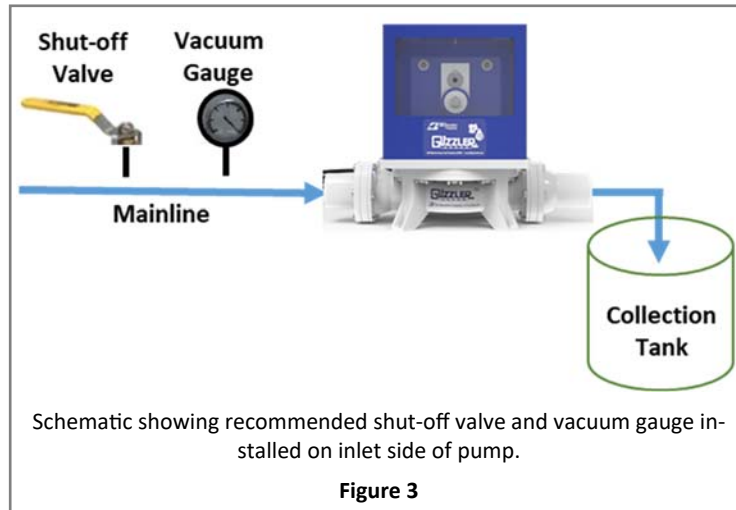

When installing your Guzzler Pump, we recommend that you install a shut-off valve and a vacuum gauge – in that sequence – “in front of” the pump; i.e., just before your connection to the pump’s inlet port. (Figure 3)

If you experience a loss of vacuum in your system – as registered in the gauge near the pump – slowly turn the shut-off valve to isolate the pump from your mainline. **DO NOT SHUT THE VALVE SUDDENLY, AS PUMP DAMAGE MAY RESULT.** If the gauge begins to return to normal operating vacuum, then the pump is working properly and the source of the leak is somewhere in your sap lines or taps. If, on the other hand, the pump fails to recover normal vacuum, then the pump is the source of the problem, and you should inspect the pump diaphragm and/or valves for any holes or tears. In the case of the valves, check for any material that may have entered the pump and lodged in the valve body, preventing the valve from proper opening and closing.

The motor on your Guzzler Pump has a built-in cooling fan to keep from overheating. Ensure that the motor has adequate airflow during operation or it will overheat. Even with adequate ventilation, you may notice that the motor becomes uncomfortably hot to touch during pump operation. This is normal. The surface temperature of the motor can become as hot as 175°F (~80°C) during pump operation. If the motor overheats, an internal thermal sensor will shut the motor off. Should this happen, allow the motor to cool before attempting to restart the pump.

If there is a risk of freezing conditions, we recommend that you disconnect the pump from your sap lines when the pump is not running and drain any excess sap from the pump. Sap can freeze within the pump bodies or lines. If this happens and the pump is turned on, it will result in damage to various pump components, including pump bodies, valves and diaphragms. We recommend flushing the pump (i.e., letting it pull a full volume of water) and then draining any remaining water from the pump to help prevent freezing.

To shut the pump down and disconnect it from the mainline, first turn the pump off. Then, close the shut-off valve to isolate and maintain some vacuum in the mainline. Then disconnect the pump from the mainline, using Quick Couplers if you have used these for your pump-to-mainline connection. Turn the pump back on briefly to flush any remaining sap from it. Finally, tilt the pump to drain any remaining sap.

Maintenance - Changing the Diaphragm

Over time, the elastomer components of the pump (i.e., the diaphragm and valves) will fail. Diaphragms tend to develop a hole or tear. If the diaphragm fails, the pump will continue to operate, but will be unable to create or maintain a vacuum. Additionally, you will notice sap leaking from the diaphragm and out around the pump guard. Your Guzzler pump ships with a spare diaphragm. Additional replacement diaphragms can be purchased through your local maple sap equipment dealer and directly from our website (www.thebosworthco.com). Note that the GE-0401x and the GE-0501x pumps use the same size diaphragm.

When replacing the diaphragm, close attention should be paid to the orientation of various parts. The use of witness marks may be helpful during reassembly.

1. Disconnect the power.
2. Turn the pump upside down so that it is resting on the pump guard and motor. With a pencil, mark the side of the mounting plate next to the pump inlet (the shorter of the two ports).
3. Remove the 10 screws holding the pump body to the aluminum mounting plate. (Figure 4)
4. Remove the pump body to expose the diaphragm screw attaching the plastic "button" (a plastic support plate) to the diaphragm.
5. Remove the slotted head screw, washer, button and diaphragm from the aluminum connecting rod. (Figure 5)
6. Ensure the top button (rounded edge side toward diaphragm) and stainless steel washer are properly seated on the connecting rod, and then place the new diaphragm onto the top button. Reinstall the bottom button (rounded edge side toward diaphragm) and stainless steel washer onto the diaphragm and secure all with the diaphragm screw. Note: Be sure to place the diaphragm on the connecting rod so that the ridge running along the diaphragm's circumference is facing toward you. (The other side of the diaphragm's outer edge is flat.) Be sure the screw is tight. We recommend using blue Loctite on the screw to help ensure it does not come loose during pump operation.
7. Place the pump body up against the diaphragm and align it with the holes on the Intermediate Ring and Mounting Plate. Be sure that the diaphragm's outer lip sits in the groove running around the circumference of the pump body. (Figure 6) (Note: Ensure the pump body is installed in the correct orientation, with the inlet next to the mounting plate witness mark made in Step 2.)
8. Fasten the pump body to the mounting plate using the 10 screws and nuts. Start all screws and nuts before tightening them down. Tighten to a maximum of 30 in-lbs of torque. Tighten screws evenly (crisscross pattern). Do not completely tighten screws until everything is aligned.

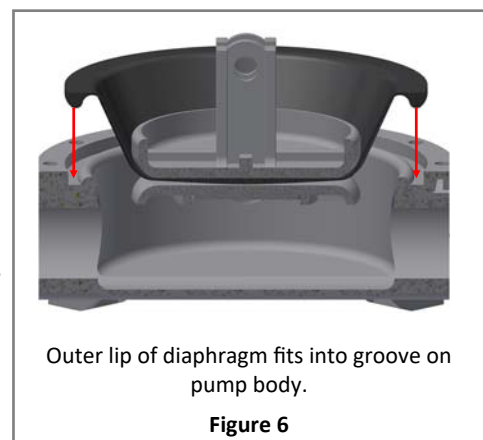

There are two valves in each Guzzler pump. One valve is located between the pump body and the inlet port; the other, between the pump body and the outlet port. Your Guzzler pump may be equipped with either duckbill valves or umbrella valves, depending on the pump options chosen.

The duckbill valve is shaped like a bird's beak. When pressure is placed on the outside of the beak, it forces it to close; when pressure is placed on the other end of the valve, it forces the beak to open so that fluid may pass. (Figure 7A-B) The duckbill valve on the GE-0501x series pumps is slightly larger than that on the GE-0401x pumps.

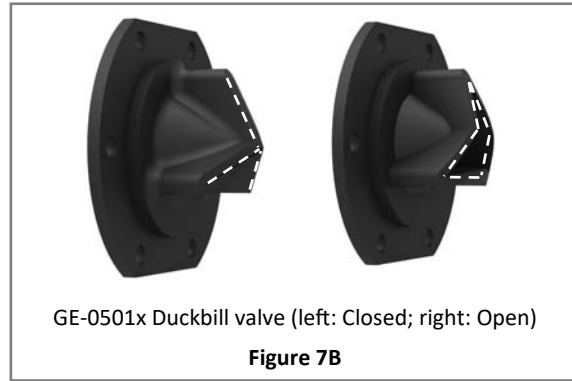
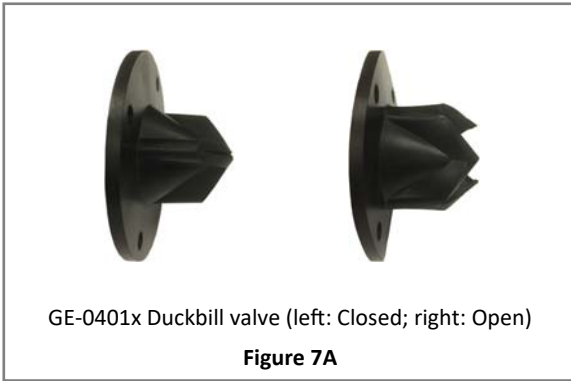

The other kind of valve available for your pump is an umbrella valve. The umbrella valve features a rubber valve with a flat round disk held under tension against a plastic plate (the "valve stop") that contains a number of holes or "pores". (Figure 8)

When pressure is applied to one side of the valve stop, it pushes the rubber disk away from the holes, like an umbrella turning inside out. (Figure 9A-B) When this happens, fluid or air can pass through the holes. When the pressure is reversed, the rubber disk is forced against the holes, making a tight seal to prevent any fluid or air from passing.

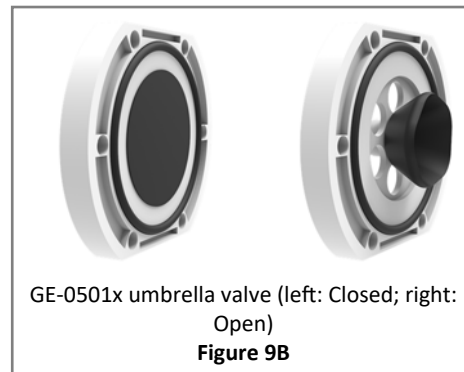
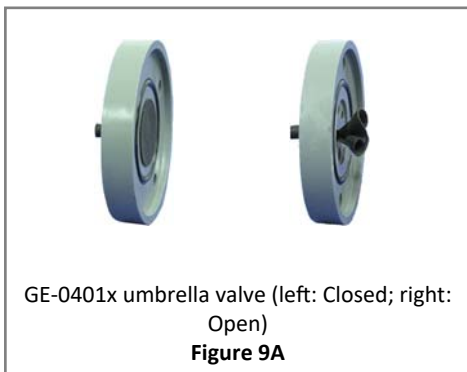
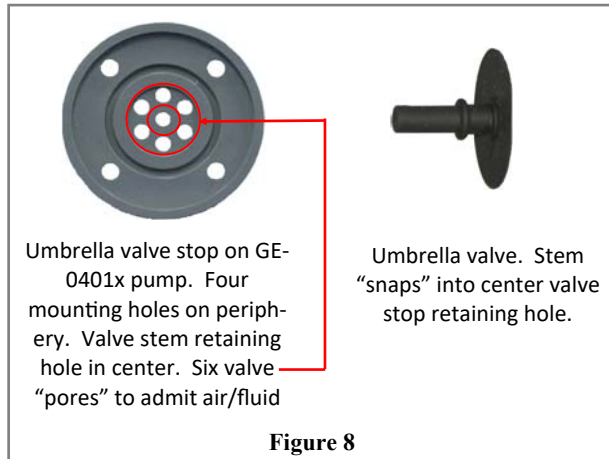

Either kind of valve can be fouled by material in the sap (e.g., wood shavings from taps, plastic shavings from tubing, etc.) that is too large to pass through the valve. When this happens, the diaphragm will be unable to develop any vacuum. However, unlike the case of a diaphragm failure, valve malfunction will not result in any sap leaking from the pump. If you were to disconnect the pump from your tap lines and perform the simple pump check described on page 3, you would feel no vacuum pulling from the inlet port. To correct the problem the valve should be removed, inspected and cleaned. Several of the steps involved in doing this are the same as the steps required to change a valve. (Instructions on changing valves are provided on page 7.)

Maintenance - Changing Pump Valves

In the case of the umbrella valve, material may become lodged in the umbrella valve pores, preventing the rubber umbrella valve from sealing tightly against the valve stop. The duckbill valve is generally better able to pass fluid containing some debris or material. Nonetheless, it is also possible for material to become lodged in the valve, preventing it from properly closing, resulting in loss of vacuum. If there is a loss of vacuum, inspect the valves and remove any foreign material that may be obstructing valve function.

Valves are typically replaced in pairs; i.e., the inlet and outlet valve of a given pump body are replaced at the same time. The process of valve replacement is similar whether your pump contains duckbill valves or umbrella valves. Care must be taken to install the valves in the proper orientation.

Duckbill valves must be installed so that their **pointed edge points in the direction of fluid flow**. (Figure 10A) On the inlet side, the duckbill valve points into the pump body; on the outlet port, it points away from the pump body.

Umbrella valves have a flat side and a side with a valve stem. **Umbrella valves** must be installed so that their **valve stems point in the opposite direction to fluid flow**. (Figure 10B) On the inlet side, the umbrella valve stem points away from the pump body; on the outlet port, the stem points toward the pump body.

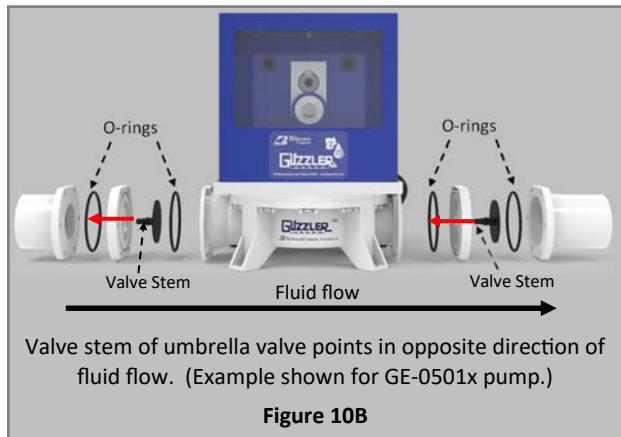
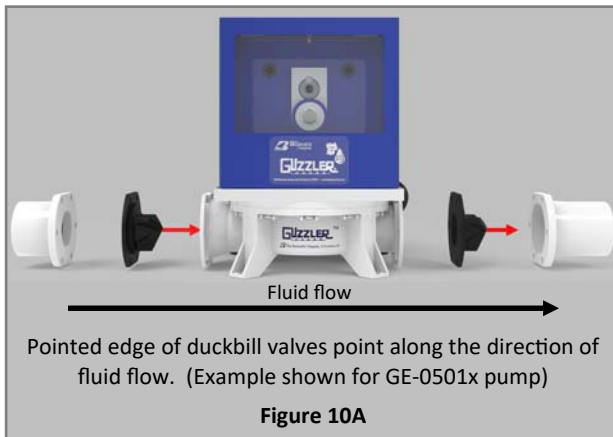

Changing Pump Valves

NOTE: When replacing a pair of pump valves, it is best that only one valve is removed and replaced before attempting to remove and replace the other valve.

1. Disconnect the power.
2. Remove the screws holding the inlet flange to the pump body. (Figure 11) (GE-0401x pump has 4 screws; GE-0501x has 6 screws.) The valve is located between this flange and the pump body.



3. Inspect the valve for any tears. Remove any dirt or material that may have become lodged in the valve. For umbrella valves, inspect O-rings in valve stop for any sign of wear and replace as necessary. Ensure that they are correctly installed in the valve stop grooves. (Figure 12)
4. To replace an umbrella valve, use a pair of pliers to grasp the flat portion of the old umbrella valve and pull the entire valve through the valve stop center retaining hole. (Figure 13) Insert the stem of the new valve into the valve stop retaining hole so that the flat portion of the valve is on the same side of the valve stop as the old valve. Use pliers to grasp the stem of the valve on the other side and pull it completely through until it snaps into place.
5. Position the new valve (or the inspected and cleaned old valve) between the pump body and the pump inlet flange, taking care to orient the valve as shown in Figure 10 on page 7. Fasten the pump flange and, for umbrella valves, the valve stop to the pump body using the flange screws.
6. Repeat steps 2-5, this time with the outlet side of the pump. **Be sure to install the outlet valve so it is oriented as shown in Figure 10.**



Umbrella valve stop with O-ring installed in grooves. (Example shown for GE-0401x pump.)

Figure 12

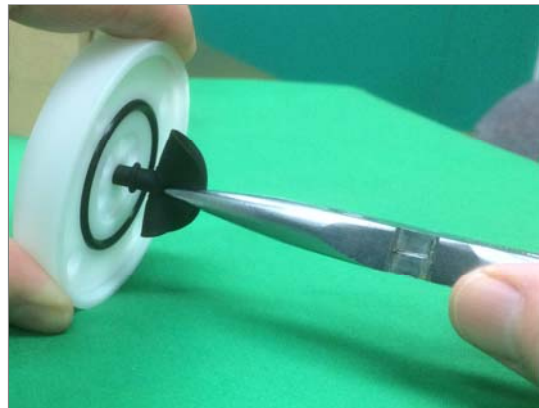

Use pliers to remove old umbrella valve from valve stop. (Example shown for GE-0401x pump.)

Figure 13

NOTE: IF THE VALVES ARE NOT ORIENTED CORRECTLY IN THE PUMP FLANGES, THE PUMP WILL NOT FUNCTION PROPERLY AND COULD BE DAMAGED UPON OPERATION.

Maintenance - Rod End Bearing Lubrication on Older Models

Guzzler 115 VAC pumps that shipped prior to 10/1/2016 were equipped with a motor linkage that featured a rod end bearing with a grease fitting that required periodic lubrication. Guzzler 115 VAC pumps that shipped subsequent to 10/1/2016 were equipped with a connecting rod that featured a self-lubricating bearing and need no lubrication.

If your Guzzler has a grease fitting on its connecting rod, we recommend that the bearing be lubricated every 400 hours of operation or, more frequently, if operating conditions are such that the bearing begins to make a squeaking noise. The fitting can be accessed by removing the screw that attaches the front of the pump guard to the back of the guard plate. (Figure 14) Slide the front of the pump guard off the plate to reveal the grease fitting. (Figure 15) The fitting can be lubricated with standard multi-purpose NLGI Grade 2 lithium grease.

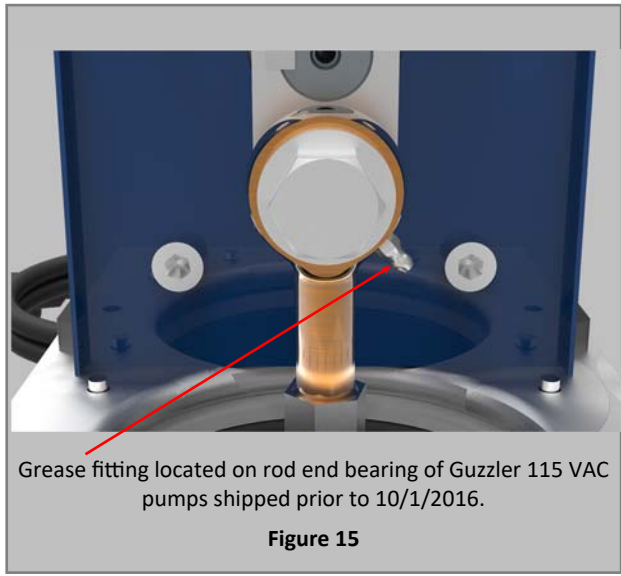

Replacement Parts

Your Guzzler pump comes with a replacement diaphragm. The Bosworth Company sells a full line of replacement parts for your pump, including replacement diaphragms and valves.

You can order replacement parts directly through your distributor or by going on our website at www.thebosworthco.com