

# Guzzler® GE-0401D

Note:

A part is specified by ...

**Pump Family Model No. + “. ” +**

**Item No.**

e.g. **GE-0401D.4** (Clevis)

ITEM	PART NAME
1	Inlet Flange
2	Outlet Flange
3B	Bottom Button & SS Washer
4	Clevis
4B	Connecting Rod with Bearing
5	Body
6B	Intermediate Ring
7C	Motor Mounting Plate
12	Misc. Hardware (10-24 Screws & Nuts)
12C	TH1/4-20x1/2 (1) Diaphragm Screw
13	Diaphragm
14	Flapper Valves
15	Umbrella Valves (Umbrella valves (2), Valve Stops (2), O-rings (4), Screws & Nuts)
16	Duckbill Valves
18C	Connecting Rod Bolt w/spacers
19A	Crank Arm (18mm) w/1/4-20 Set screws (2)
19B	Crank Arm (5/8in) w/1/4-20 Set screws (2)
20	Motor Mounting Bracket & Bolts (4)
21	Gearmotor
22	Switch Box w/Toggle Switch, Capacitor, power & motor cords and connectors
23	Pump Guard
PS-GE	Pin Set for GE pumps

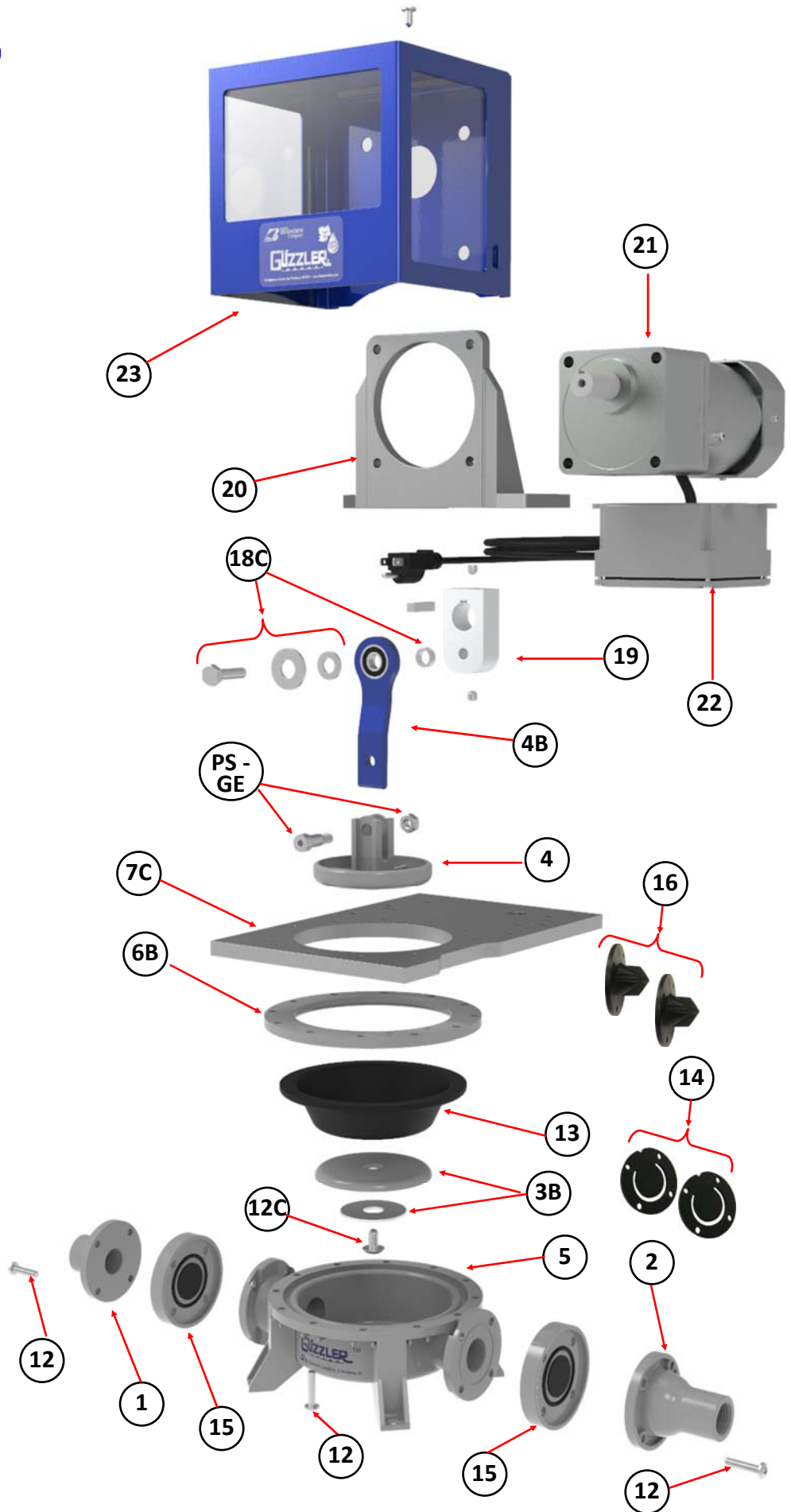

930 Waterman Avenue East Providence, RI  
02914  
Ph: 401-438-1110 888-438-1110 Fax: 401-438-2713