

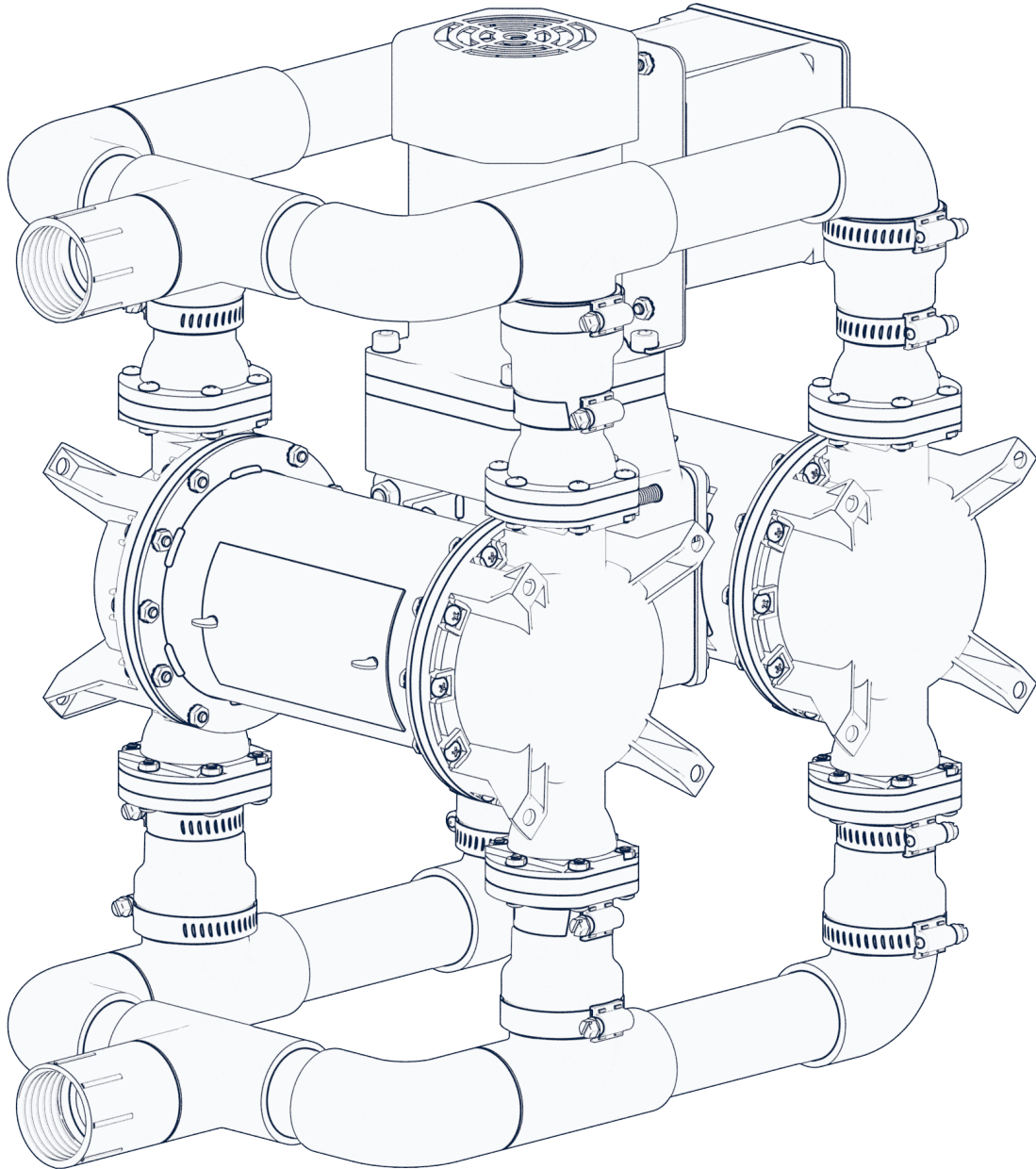

## QUAD DIAPHRAGM PUMP

GUZZLER® G4-0501N



## OPERATOR'S MANUAL

[WWW.THEBOSWORTHCO.COM](http://WWW.THEBOSWORTHCO.COM)

**INDEX**

**INTRODUCTION..... 2**

    Power Requirements..... 2

    Testing the Pump..... 2

**PUMP SETUP ..... 3**

    Protect the Pump from the Elements..... 3

    Ventilate Pump to Keep from Overheating..... 3

    Quick Connect Couplers between Guzzler and Mainline..... 3

    Install Shut-off Valve and Vacuum Gauge at Pump Inlet ..... 3

    Use a Strainer to Keep Foreign Materials and Ice from Entering the Pump ..... 4

    Minimize Pump Back Pressure ..... 4

    Recirculation Line for Best Vacuum ..... 4

**TIPS FOR BEST OPERATION ..... 4**

    Eliminate Leaks for Best Vacuum ..... 4

    Isolate the Pump to Find Cause of Vacuum Loss ..... 4

    Keep Ice from Forming Inside Pump..... 4

    Drain Sap if Removing Pump from Mainline..... 4

**MAINTENANCE - CHANGING A DIAPHRAGM ..... 5**

    Replacing a Diaphragm ..... 5

    Steps to Remove a Diaphragm ..... 5

    Installing a Diaphragm..... 6

**MAINTENANCE - CHANGING PUMP VALVES..... 7**

    Pump Valves ..... 7

    Changing Pump Valves..... 7

**TROUBLESHOOTING ..... 8**

**TECHNICAL SUPPORT..... 8**

**PUMP EXPLODED VIEW ..... 9**

Your Guzzler Quad Pump ships with the pump manifolds removed. Use the flex couplers (see Figure 3, page 5) to attach the pump manifolds to the pump inlet and outlet flanges (Figure 1), tightening the flex coupler hose clamps for a secure connection. Note that you can install the manifolds with the inlet and outlet manifold ports pointing in the same or opposite directions.

Included with the pump is a set of 4 spare diaphragms. Additional diaphragms can be purchased through your maple equipment dealer or directly online from The Bosworth Company at [www.thebosworthco.com](http://www.thebosworthco.com).

Your pump's **serial number** can be found on the side of the pump gear-motor, as shown in Figure 1.

Power Requirements

The pump on/off switch is located at the top of the electrical junction box.

The Quad Pump requires 120V AC power. The pump motor draws 3 amps at full load.

The pump can be powered by a generator or DC to AC inverter, but any such power source must provide a clean, pure sine wave signal, not a truncated or simulated sine wave. Overvoltage or undervoltage power sources may cause the motor to overheat, which could cause the motor to shut off and/or result in motor damage, voiding the pump warranty.

Testing the Pump

Before installing the pump in your sugarbush, test your pump by connecting it to power and turning the power switch to On. Carefully cover the inlet port (on the bottom manifold) with your hand. Then move your hand to cover the outlet port of the pump. If you can feel vacuum at the inlet port (sucking your hand in) and positive exhaust pressure at the outlet port (pushing your hand away), the pump is operating properly.

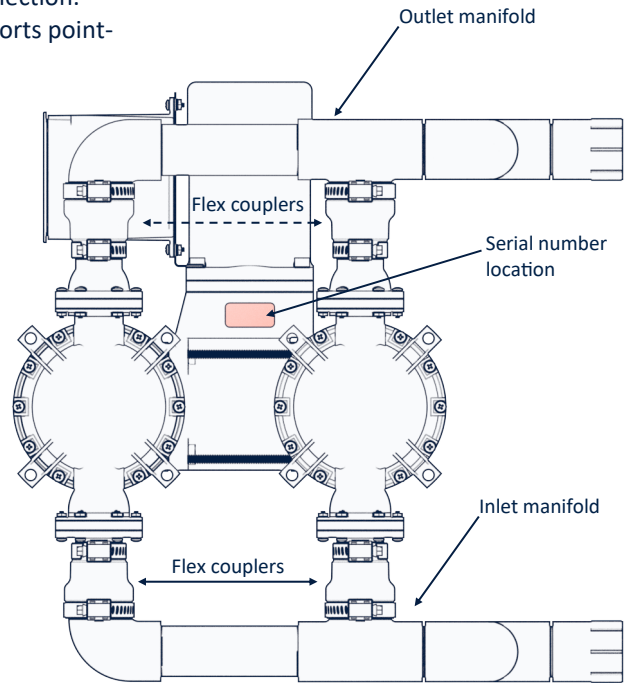

Pump with attached manifolds  
**Figure 1**

**IMPORTANT SAFETY INFORMATION**

**NEVER OPERATE YOUR GUZZLER PUMP WITHOUT THE PUMP HOUSING COVER PLATES PROPERLY INSTALLED ON THE PUMP.**

**NEVER REACH INSIDE THE PUMP OR INSERT ANY OBJECTS INTO THE PUMP WHILE THE PUMP IS OPERATING. SERIOUS INJURY OR DAMAGE TO THE PUMP WILL RESULT.**

**ALWAYS CONNECT THE PUMP TO A 120 VAC POWER SOURCE USING PROPERLY INSULATED CONNECTORS. OPERATING THE PUMP WITHOUT PROPER ELECTRICAL CONNECTIONS CAN CREATE A SERIOUS RISK OF ELECTRICAL SHOCK.**

## PUMP SETUP

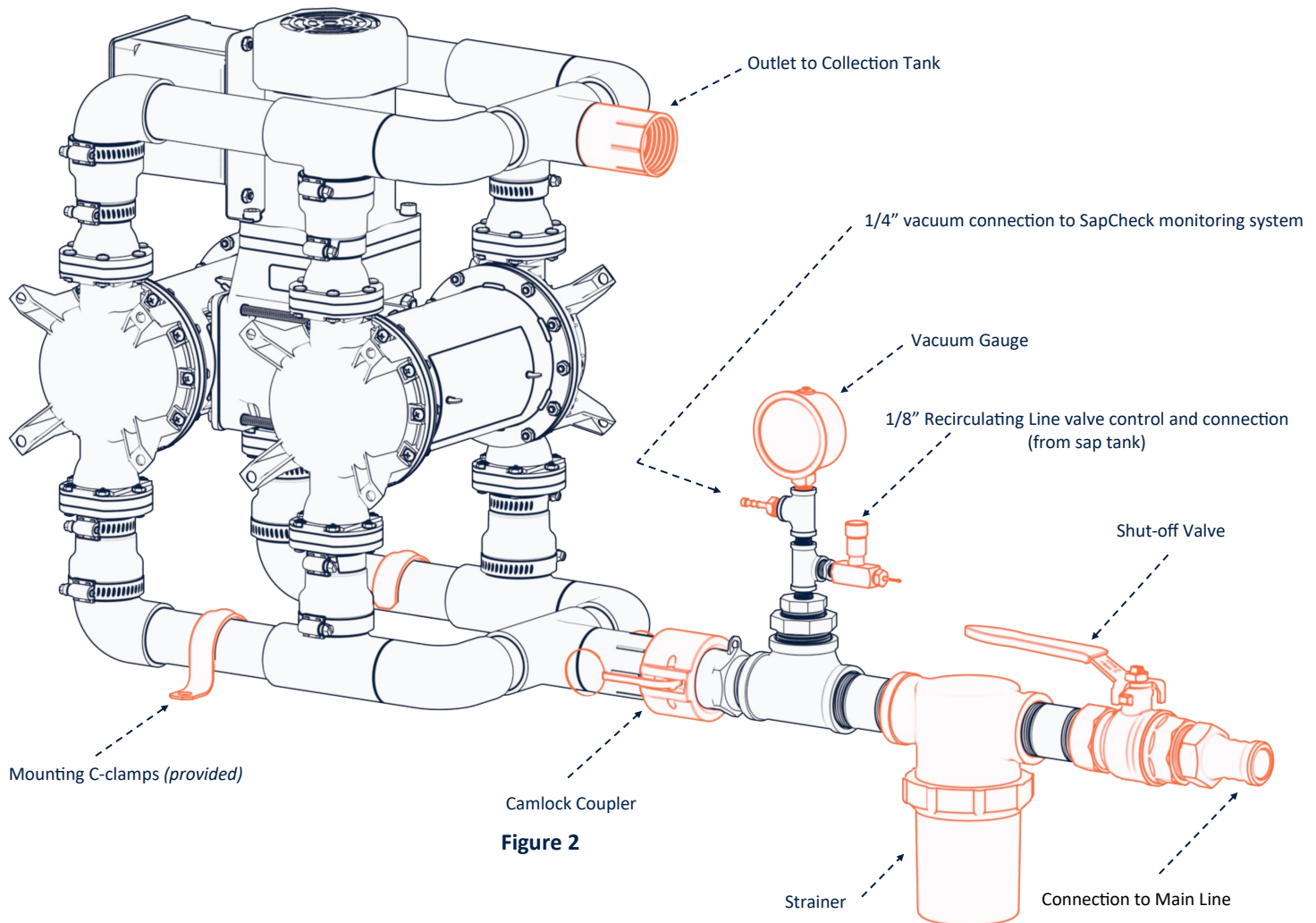

**Figure 2**

Figure 2 shows the recommended installation setup for the Guzzler Quad pump when used for vacuum production on a maple sap collection line. The topics below refer to that figure in more detail.

### Protect the Pump from the Elements

However you deploy your pump, ensure it is protected from the elements and securely mounted. Use the two C-clamps provided to secure the inlet manifold to a mounting surface.

### Ventilate Pump to Keep from Overheating

When operating, the pump can develop a motor surface temperature that may exceed 160°F (70°C). If you install your pump in an enclosure, ensure that it provides ventilation so that the pump motor has adequate airflow during operation to prevent overheating.

### Quick Connect Couplers between Guzzler and Mainline

Your Guzzler pump is fitted with 1-1/4" female NPT connectors that allow you to plumb it into your sap lines. We recommend the use of camlock couplers between the pump inlet and mainline so that the pump can be easily disconnected from and reconnected to your mainline.

### Install Shut-off Valve and Vacuum Gauge at Pump Inlet

We recommend that you install a shut-off valve and a vacuum gauge "in front of" the pump, i.e., just before your connection to the pump's inlet port. This will allow you to isolate the pump from your sap lines for trouble-shooting purposes.

### Use a Strainer to Keep Foreign Materials and Ice from Entering the Pump

Early in the season, sap may contain small wood or plastic shavings that can foul or tear the pump valves or diaphragm. (Even sharp ice chips, upon entering the pump, can create the same problem.) We recommend installing a strainer to keep such material from being drawn into the pump. A strainer with a transparent cap will allow you to see when the filter screen needs to be cleaned so that it does not obstruct sap flow into the pump.

### Minimize Pump Back Pressure

Back pressure at the pump outlet will shorten diaphragm lifetime. To minimize back-pressure, install your Guzzler at or above your collection tank level. Avoid having the pump “push” sap up more than 1-2 ft of vertical distance or through a long outlet hose or pipe. Avoid the use of right-angle bends in the pump’s outlet path, as these can add substantially to back pressure.

### Recirculation Line for Best Vacuum

Guzzler pump valves seal best when wet. To achieve the best vacuum with your Guzzler, we recommend that you install a small (1/8”) recirculation line from your collection tank back to the inlet of the Guzzler. Regulate this backflow of sap by installing a needle valve where the line connects to the inlet. When the pump is running, open the valve to allow a small amount of sap to flow back from the collection tank into the pump. This ensures the valves remain wet and seal optimally. The use of a recirculating line can allow the pump to create vacuum as high as 28 in Hg.

## TIPS FOR BEST OPERATION

### Eliminate Leaks for Best Vacuum

Your Guzzler Pump can develop 19-28 in. of Hg vacuum, depending on whether the valves are dry or wet. Because the Guzzler is a low-cfm (cubic feet of air per minute) pump, even very small leaks can prevent the pump from delivering its rated vacuum. Maintain your tap lines to keep your system tight and address problems that can cause vacuum leaks.

### Isolate the Pump to Find Cause of Vacuum Loss

If you experience a loss of vacuum in your system – as registered in the gauge near the pump – slowly turn the shut-off valve to isolate the pump from your mainline. **DO NOT SHUT THE VALVE SUDDENLY, AS PUMP DAMAGE MAY RESULT.** If the gauge begins to return to normal operating vacuum, then the pump is working properly, and the source of the leak is somewhere in your sap lines or taps.

If the pump fails to recover normal vacuum then you should inspect the pump diaphragms and/or valves for any holes or tears. In the case of the valves, check for and remove any material that may have entered a pump body and lodged in the valve, preventing the valve from proper opening and closing.

### Keep Ice from Forming Inside Pump

Sap can freeze within the pump bodies. If the pump is turned on when there is ice in a pump body, it can result in damage to various pump components, including pump bodies, valves and diaphragms. If there is a risk of freezing conditions, we recommend that you disconnect the pump from your sap lines when the pump is not running and drain any excess sap from the pump. Some users install a small heat lamp in the enclosure with the pump to prevent ice from forming when the pump is not operating.

### Drain Sap if Removing Pump from Mainline

To drain the pump, shut it down and disconnect your mainline. Tilt or rotate your pump so that the outlets face down, and restart it to drain any sap remaining in the pump bodies.

**MAINTENANCE - CHANGING A DIAPHRAGM**

Replacing a Diaphragm

Over time, the elastomer components of the pump (i.e., the diaphragm and valves) will fail. If a diaphragm fails in your Quad pump, the pump will continue to develop vacuum due to the action of the remaining functional diaphragms, but sap flow through the pump may be reduced from its normal volume. When a diaphragm fails, sap will leak from the diaphragm into the tubular housing to which the pump body with the leaking diaphragm is attached, draining out through either of the two drain holes at the bottom of the crank housing.

Tools Needed: Philips Head Screwdriver, Flat Head Screwdriver

Materials Needed: Blue Loctite 242

Steps to Remove a Diaphragm

1. Disconnect the power. Failure to do so could result in serious injury and pump damage.
2. Remove the inlet and outlet manifolds by loosening the hose clamps on the flex couplers holding the manifolds to the pump flanges (Figure 3).
3. Place the pump assembly on its side, with two pump bodies facing up.
4. Next, remove the 10 screws holding each pump body to the blue crank housing. Remove two pump bodies. Also, remove the thumb screws holding the housing cover plates in place, so you can see the connecting rods (Figure 4).
5. With the pump bodies off, rotate the crank arm (push on the crank bolt while pulling/pushing on a diaphragm assembly. In its natural molded state, the diaphragm extends fully into the pump body which you just removed (Figure 5).
6. Note the orientation of the plastic button that secures the diaphragm. The rounded edge of this button faces the diaphragm (Figure 7). The diaphragm screw is secured with Blue Loctite 242 from the factory, which must be re-applied upon reassembly.

*Note: If you plan to change the valves, do so now. (See section **Maintenance – Changing Pump Valves.**)*

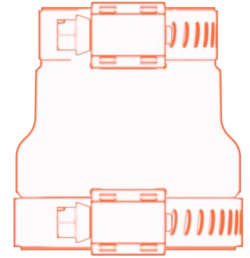

Manifold flex coupler & hose clamps  
**Figure 3**

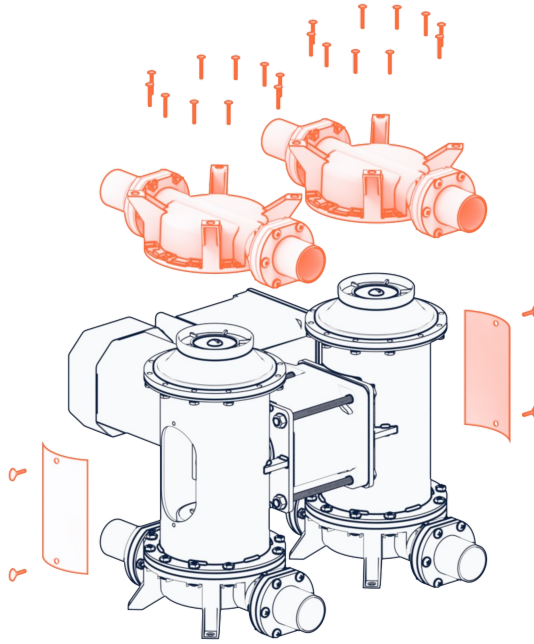

**Figure 4**

Diaphragm at bottom of stroke (fully extended into pump body)

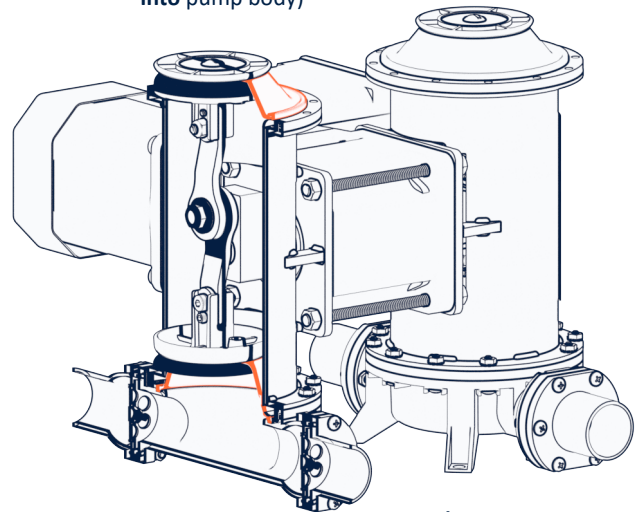

**Figure 5**

Diaphragm at top of stroke (fully extended out of pump body)

Installing a Diaphragm

7. To install the new diaphragm, first pull on the clevis to bring the diaphragm assembly toward you, so that the diaphragm is at the bottom of its stroke, extending into the pump body you removed in step 4. (Figure 5).

8. Place the new diaphragm onto the clevis, making sure the center hole of the diaphragm is stretched and secured around the boss of the clevis (Figure 6).

**Note:** Be sure to place the diaphragm on the clevis so that the O ring “lip” in the diaphragm’s outer diameter will sit in the pump body. The “dry” side of the diaphragm is flat and should face the clevis.

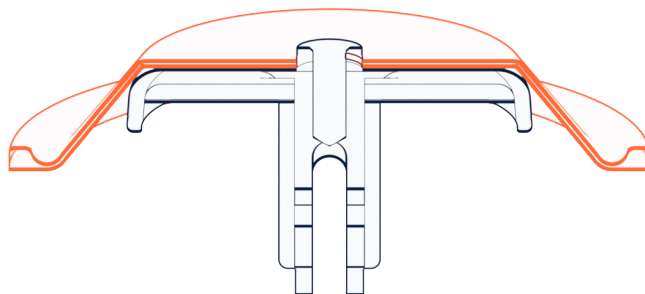

Diaphragm  
Figure 6

9. With the diaphragm in place, reinstall the plastic button (rounded edge toward diaphragm), ensuring it is seated securely on the clevis boss. Install the washers and diaphragm screw, using Blue 242 Loctite on the screw. (Figure 7.) (Set time for the Loctite is 10 minutes, so avoid running the pump until the Loctite has a chance to set.)

10. If you removed it, the intermediate ring needs to be reinstalled, placed between the diaphragm and the mounting flange of the blue crank housing tube. Fasten the body to the housing using the 10 screws and nuts (Figure 4). Reinstall the housing cover plates.

11. Once the housing cover plates are installed, but with the manifolds still removed, it is recommended to run the pump and check with your hand against the inlet and outlet of each of the four pump bodies to ensure that the pump is creating negative pressure (suction) on the inlets and positive pressure (exhaust) on the outlets. If so, then the valves and diaphragms are working properly.

12. Place the flex couplers on the pump inlet and outlet flanges. If needed, you may want to use some vegetable oil or similar food grade lubricant to help them slip over the pump flanges. Reinstall the pump manifolds, tightening the hose clamps on the flex couplers for a leak-free fit.

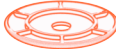
-  Screw—1/4-20, secured with Blue Loctite
-  Washers—two for all pumps with Santoprene diaphragms
-  Button—Rounded edge towards diaphragm
-  Diaphragm—ensure fully seated on clevis

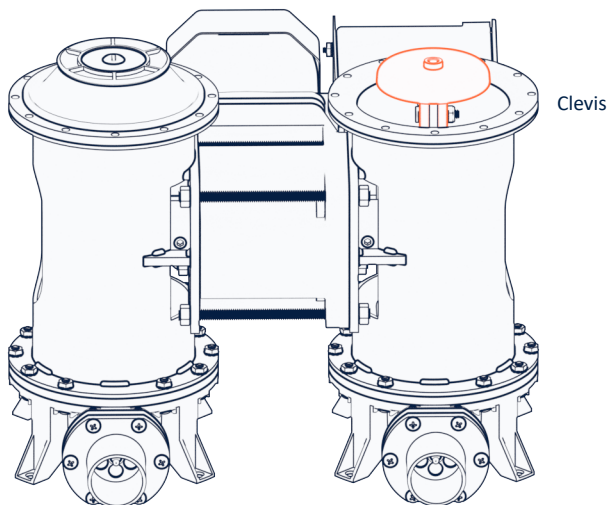

Figure 7

## MAINTENANCE - CHANGING PUMP VALVES

### Pump Valves

Each pump body in the Guzzler G4 pump features a pair of valves (a total of 8 for the Quad pump). A valve is fastened between the pump body and each of its inlet and outlet ports. (Figure 8)

Valves are typically replaced in pairs; i.e., the inlet and outlet valves of a given pump body are replaced at the same time. When replacing a pair of pump valves, it is best that only one valve is removed and replaced before attempting to remove and replace the other valve.

### Changing Pump Valves

1. If you have not already done so, follow steps 1 and 2 in *Steps to Remove a Diaphragm*. It is not necessary to remove the pump body in order to inspect or change the pump body's valves. We recommend changing only one valve at a time, to keep the operation as simple as possible.
2. Remove the 6 screws holding the inlet to the pump body. The umbrella valve is located between this flange and the pump body, inserted in a valve stop. **Note the direction that the valve is facing, and be sure to install both valves facing the same direction** (Figure 8).
3. Gently remove the umbrella valve from the valve stop with a pair of pliers, pulling and twisting the flat "plate" of the valve until the stem pops out of the valve stop (Figure 9).
4. If you intend to reuse the valve, examine the valve first for any tears. Inspect the valve stop pores and remove any dirt or material that may have become lodged in the pores. Inspect the O-rings for any sign of wear and replace as necessary. Ensure that the O-rings are correctly installed in the grooves of the valve stop.
5. To replace the umbrella valve, insert the stem of the valve into the valve stop center retaining hole. Use pliers to gently grasp the stem of the valve on the other side and twist/pull it completely through until it snaps into place.
6. Position the valve stop between the pump body and the pump inlet flange, taking care to **orient it with the valve stem pointing in the opposite direction of fluid flow and the valve "plate" pointing toward the pump** (Figure 8). Fasten the pump flange and the valve stop to the pump body using the flange screws.
7. Repeat from step 2 to inspect or change the outlet valve. **Be sure to install the outlet valve with the valve "plate" facing away from the pump as shown in Figure 8.**

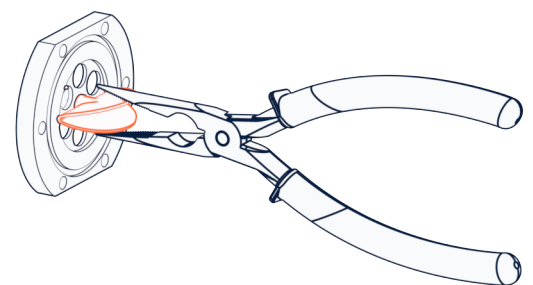
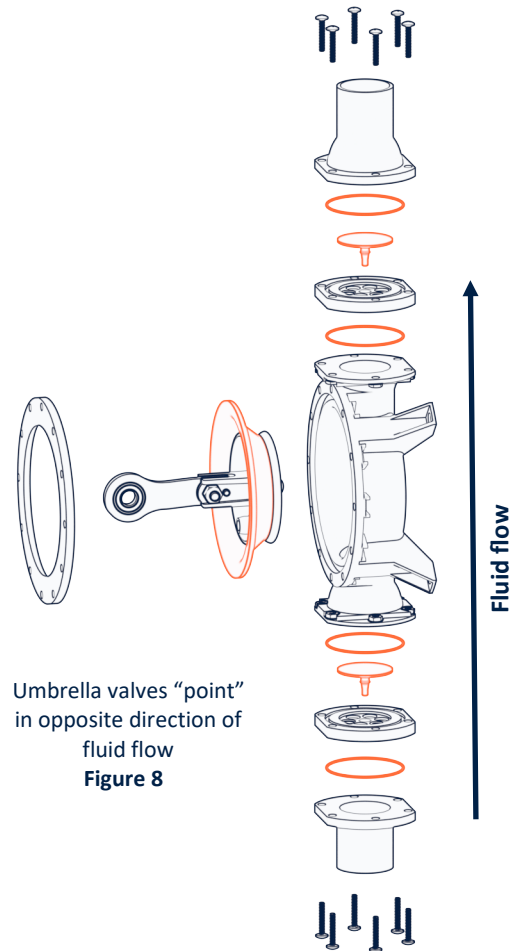

**NOTE: IF THE VALVES ARE NOT ORIENTED CORRECTLY IN THE PUMP FLANGES, THE PUMP WILL NOT FUNCTION PROPERLY AND COULD BE DAMAGED UPON OPERATION.**



**TROUBLESHOOTING**

PROBLEM	WHAT TO DO
<i>"I've got little or no vacuum on the gauge at my pump."</i>	<p>If you've installed a shut-off valve in front of the gauge, turn the valve to the off position to isolate the pump from your sap lines. If the vacuum gauge goes back up, then the pump is operating properly and you should check your lines for a leak.</p> <p>If the vacuum gauge doesn't go back up, then there is a vacuum leak at the pump. Inspect each pump to see if sap is leaking around the diaphragm. Leaking sap indicates a diaphragm is torn or has developed a hole. If the diaphragm is leaking, replace it.</p> <p>If no sap is leaking from the pump diaphragms, then disconnect the pump from your sap lines. Remove the pump manifolds (top and bottom) and, with the pump turned on, place your hand over the inlet/outlet of each pump to determine if you can feel pump suction at the inlet and exhaust pressure at the outlet. If you do not feel the suction and pressure for a pump, and there is no tear/hole in the diaphragm, then the valves are at fault. Inspect the inlet and outlet valves for the pump in question. Remove any material that might be preventing the valves from opening/closing properly. If the valves are torn or worn, replace them.</p>
<i>"The pump was working fine and then stopped."</i>	<p>Inspect your power source to ensure that it is providing 120 vac power. Ensure that you have provided adequate ventilation for the motor. The motor is thermally protected and will shut down if overheated. If this happens, allow the motor to cool down and then resume pump operation.</p>
<i>"My motor is very hot. Is something wrong?"</i>	<p>A properly operating motor can be uncomfortably hot to the touch. Even with adequate ventilation, the motors develop a good deal of surface temperature when operating. This alone does not indicate anything is wrong.</p>
<i>"My pump is frozen. Should I start it up?"</i>	<p>Do not start a pump if you suspect there is ice in any of the pump bodies. Starting a pump when there is ice in the pump bodies could tear the pump diaphragm and/or damage the pump body. Allow the pump to thaw out before restarting.</p>
<i>"I'm only getting 19-20 in Hg vacuum at the pump. How can I get more?"</i>	<p>Pump valves seal better when wet. When dry, the pump valves will generally produce 19-20 in Hg vacuum. If the valves are wet, their improved sealing can create up to 28 in Hg vacuum on leak-free sap lines. Installing a recirculating line from your sap tank back into the inlet of the pump will help keep the pump valves wet and maximize pump vacuum. (See page 4.)</p>
<i>"I've got good vacuum at the pump and there's sap in the lines, but nothing's going into my tank."</i>	<p>If you have installed a filter near the inlet of the pump, check the filter screen to ensure that it is not clogged with foreign material. A clogged filter will reduce or completely prevent sap flow through to the pump.</p>
<i>"Sap occasionally sloshes back and forth in my sap lines. Is something wrong with the pump?"</i>	<p>If you have good vacuum at the pump, this back-and-forth motion of the sap may be the natural result of the pressure inside the trees dropping to the point where it cannot push the sap out into your tap lines. This can happen as the temperature drops. When tree pressure increases, the sap will begin flowing toward the pump again, often surging for a period of time.</p>

**TECHNICAL SUPPORT**

For all technical inquiries, please refer to our website, [www.thebosworthco.com](http://www.thebosworthco.com), Maple Sap Pumps Application, or contact The Bosworth Company. Be sure to have your pump serial # readily available if contacting Technical Support. You can email us at [info@thebosworthco.com](mailto:info@thebosworthco.com) or call 401-438-1110. Technical support is available Monday-Friday, 8AM-4:30 PM. After hours support is provided as resources are available.

# GUZZLER G4-0501N QUAD PUMP - EXPLODED VIEW

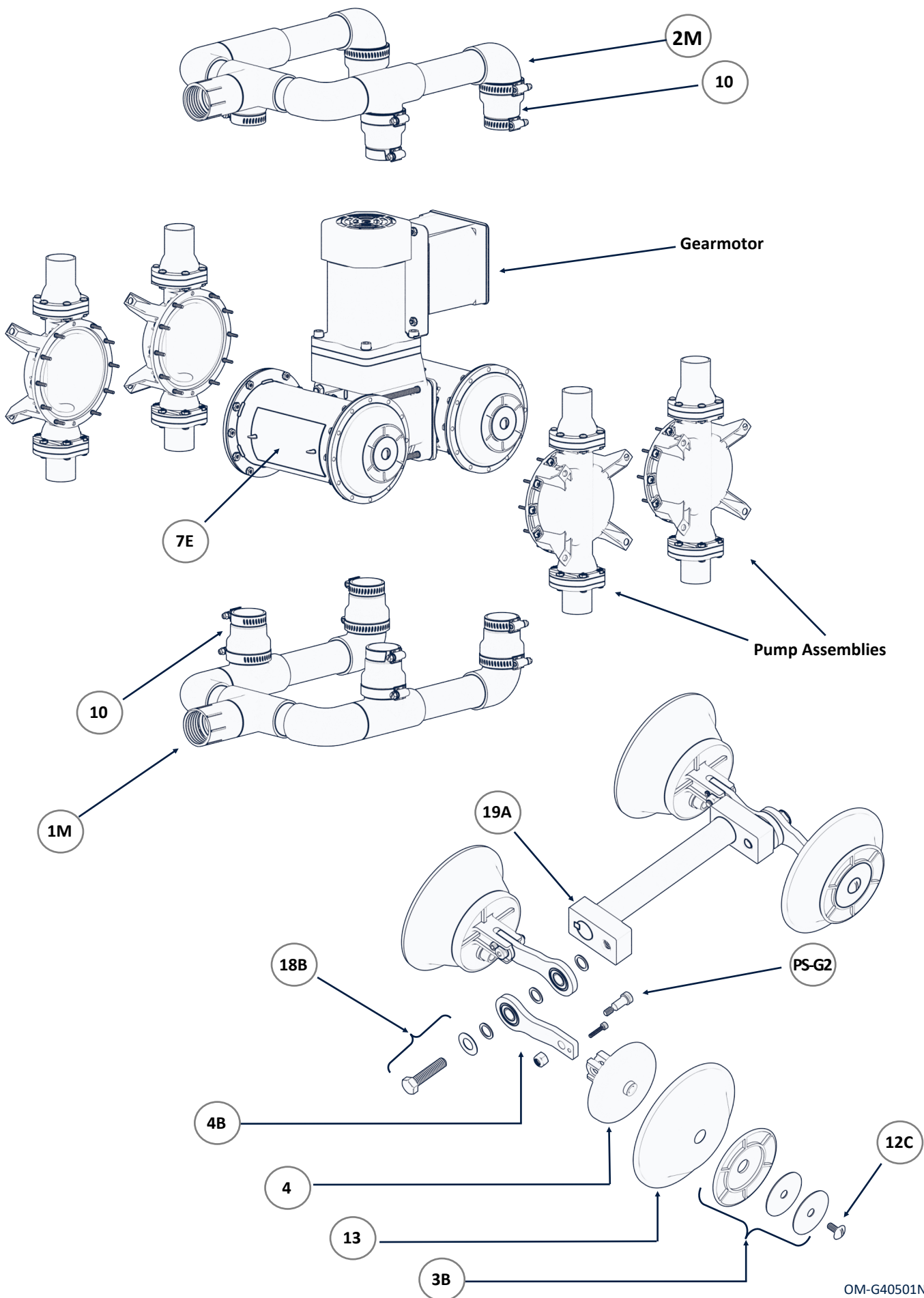

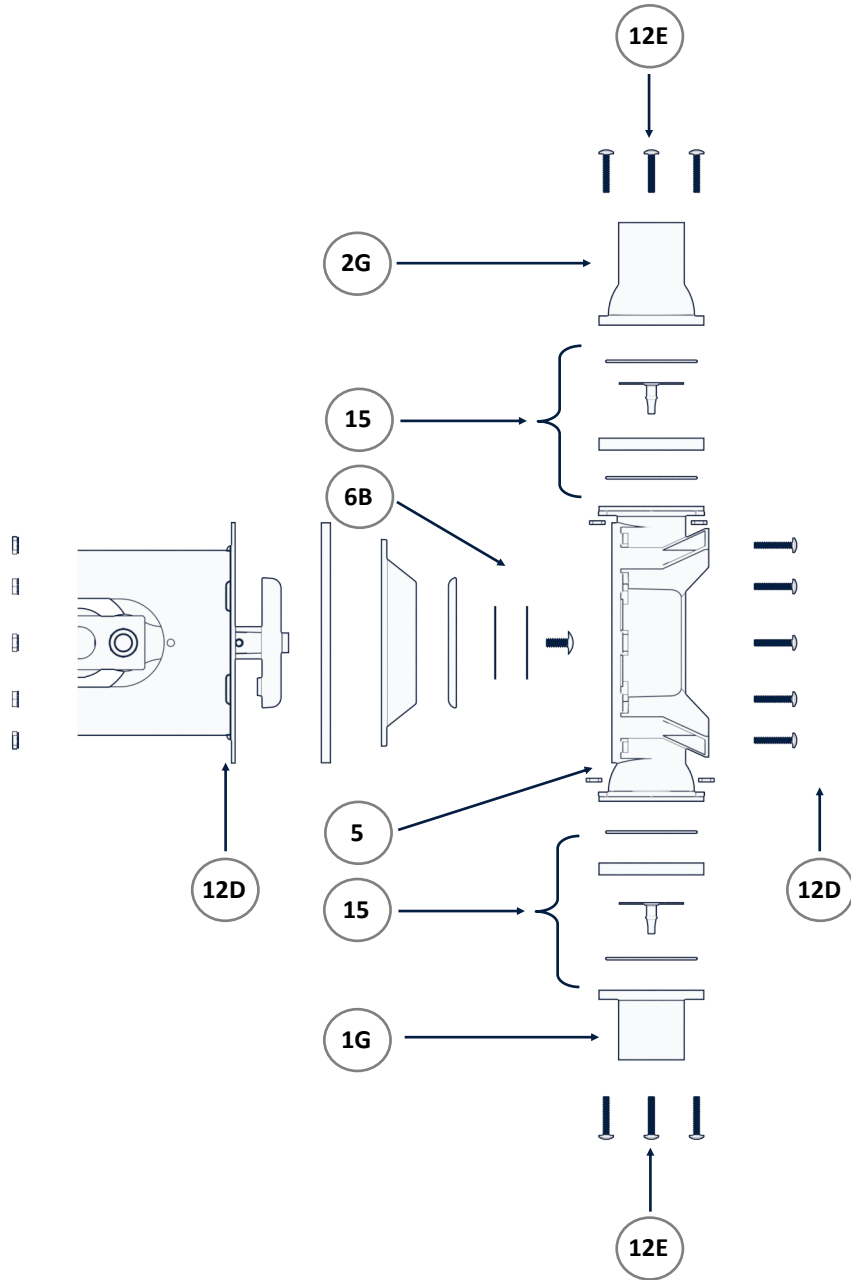

<b>Guzzler Pump Body Parts</b>	
1G	Pump Inlet Flange: 1-1/2 in smooth
2G	Pump Outlet Flange: 1-1/2 in smooth
3B	Button & Stainless Steel Washers
4	Clevis
5	Pump Body
6B	Intermediate Ring
12C	Diaphragm Screw
12D	Misc. Hardware [10-24 Screws & Nuts] (10 per pump body)
12E	Misc Hardware [10-24 Screws & Nuts] (12 per pump body)
13	Diaphragm— Santoprene (White)
15	Umbrella Valve Set: Umbrella valves (2), valve stops (2), O-rings (4), screws & nuts (1 set per pump body)
<b>Quad Assembly Parts</b>	
1M	Pump Inlet Manifold
2M	Pump Outlet Manifold
4B	Connecting Rod
7E	Housing Cover Plate
10	Flex Coupler (8) and Hose Clamps (16)
18B	Connecting Rod Bolt w/washer
19A	Crank Arm
PS-G2	Connecting Rod-Clevis Shoulder Bolt & Nut & Cap Screw



930 WATERMAN AVENUE  
EAST PROVIDENCE, RI 02914  
WWW.THEBOSWORTHCO.COM  
888-438-1110