



GUZZLER® G2-0503N
12 VDC SAPPULLER DOUBLE DIAPHRAGM PUMP



OPERATOR'S MANUAL

WWW.THEBOSWORTHCO.COM

Guzzler G2-0503N SapPULLer Pump Exploded View

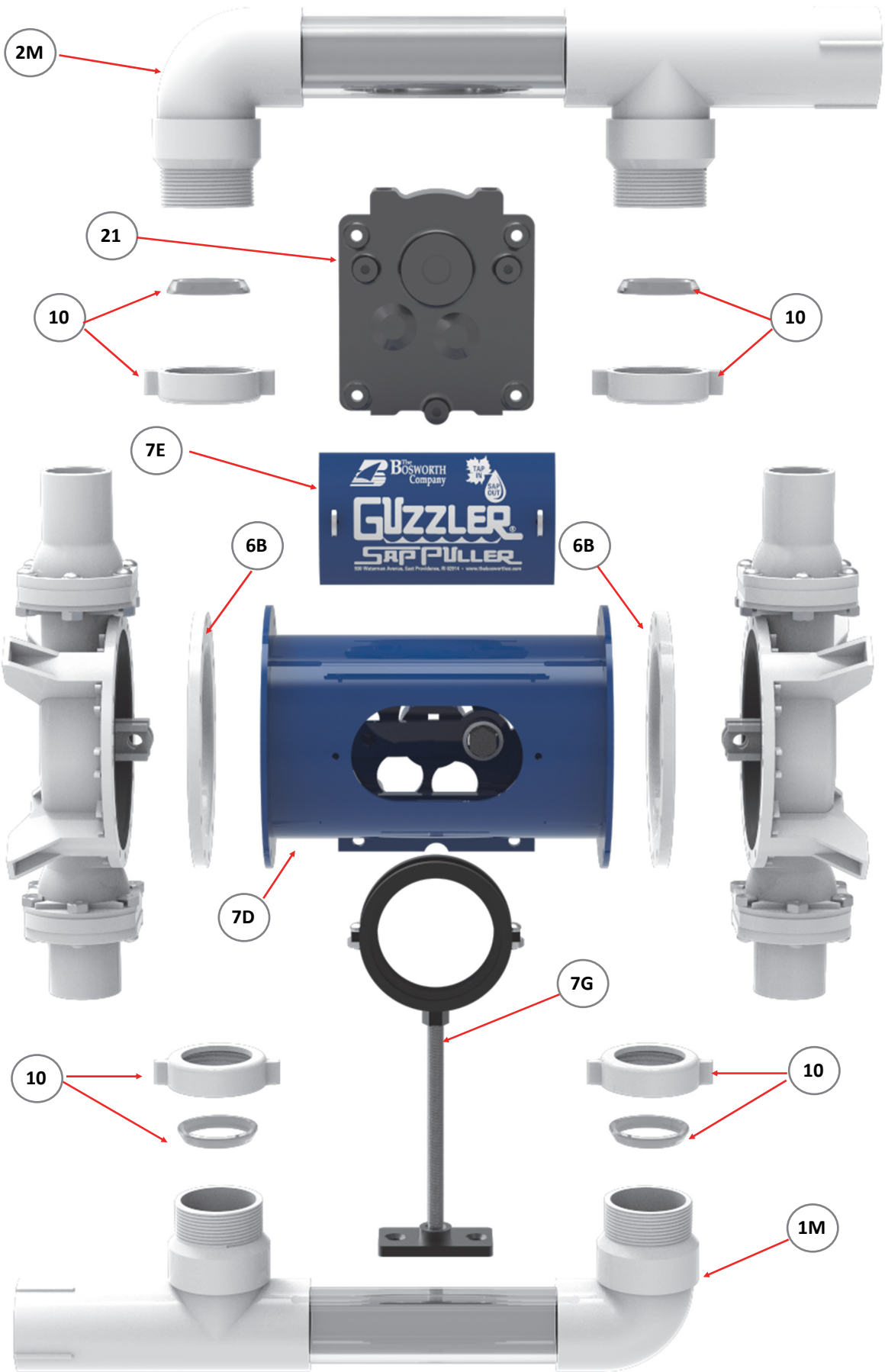

Guzzler G2-0503N SapPULLer Pump - Exploded View

| | |
|-------|--|
| 1G | Pump Inlet Flange-1/2 in smooth |
| 1M | Pump Inlet Manifold |
| 2G | Pump Outlet Flange-1/2 in smooth |
| 2M | Pump Outlet Manifold |
| 3B | Button & Stainless Steel Washer |
| 4 | Clevis |
| 4B | Connecting Rod |
| 5 | Pump Body |
| 6B | Intermediate Ring |
| 7D | Pump Housing |
| 7E | Housing Cover Plate |
| 7G | Pump Support Bracket & Leg |
| 10 | Coupler Nut (4) & Nylon Sleeve (4) |
| 12 | Misc. Hardware (10-24 Screws & Nuts) (10) (connects 1 pump body to housing) |
| 12C | Diaphragm Screw |
| 13 | Diaphragm—FDA Buna-N |
| 15 | Umbrella Valve Set: Umbrella valves (2), valve stops (2), O-rings (4), screws & nuts |
| 18B | Connecting Rod Bolt w/washers |
| PS-G2 | Connecting Rod-Clevis Shoulder Bolt & nut |
| 19A | Crank Arm w set screws (2) & key |
| 21 | GearMotor |

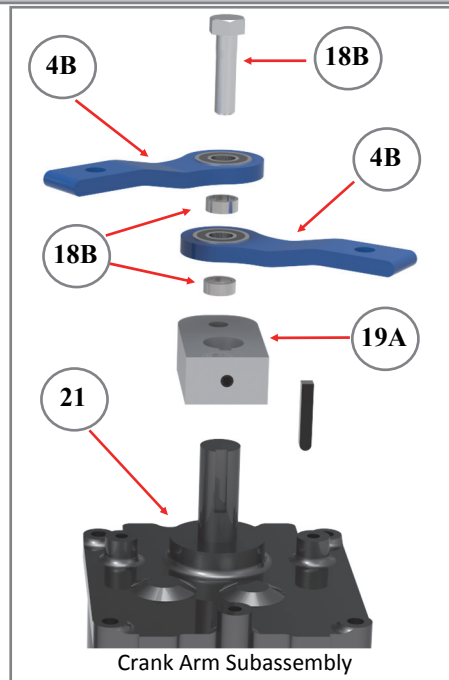
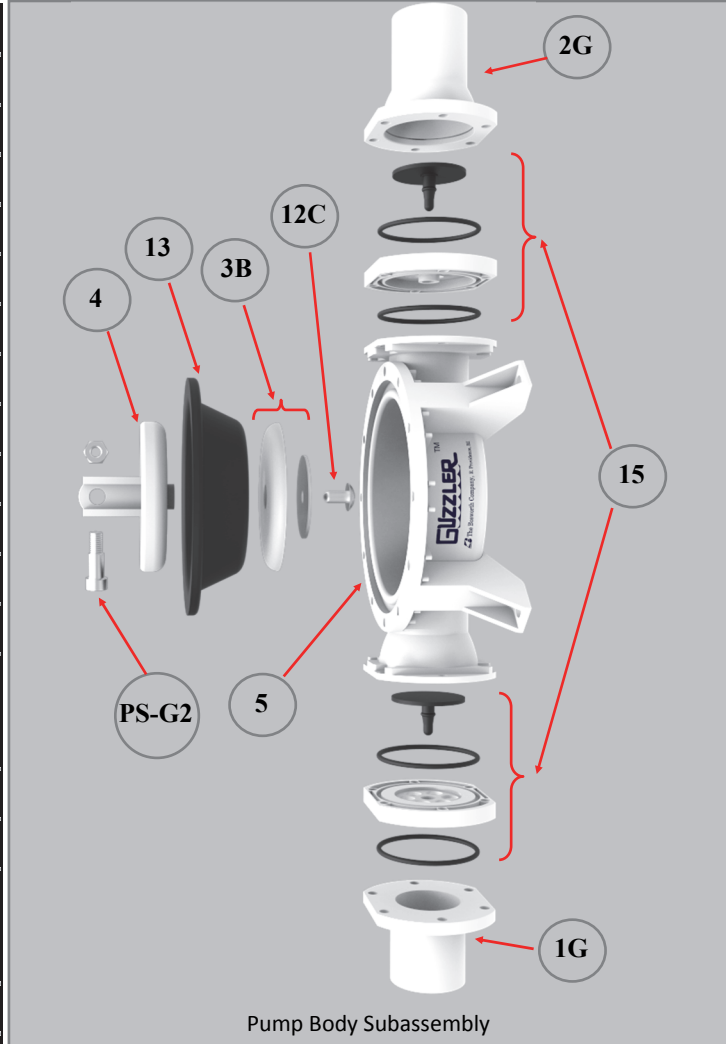

Guzzler G2-0503N SapPuller Pump Assembly & Safety Information

Assembling your Guzzler G2-0503N SapPuller Pump

Your Guzzler G2-0503N SapPuller pump ships with the outlet manifold and motor support leg disconnected from and packed separately in the box with the pump.

To assemble your pump, simply attach the outlet manifold to the twin pump bodies by slipping the manifold elbow and "T" fittings over the outlet flanges of the pump bodies. (Figure 1a)

Secure the manifold to each pump flange by tightening the Coupler Nut (#10 on page 1) on the pump flange onto the threaded ends of the manifold. The nut forces the nylon sleeve (#10A) against the manifold to make a secure, leak-free connection.

Note that you can connect the outlet manifold to your pump so that the outlet end of the manifold is on the same side as the end of the inlet manifold, or the opposite side. (Figure 2) Similarly, the inlet manifold can be connected to your pump with the inlet end facing in either of these two possible directions. Choose an orientation for your inlet and outlet manifolds that best suits the orientation of your incoming and outgoing sap lines.

Additionally, screw the threaded rod of the motor support leg into the support base until it is flush with the base end. Screw the other end into the motor support bracket.

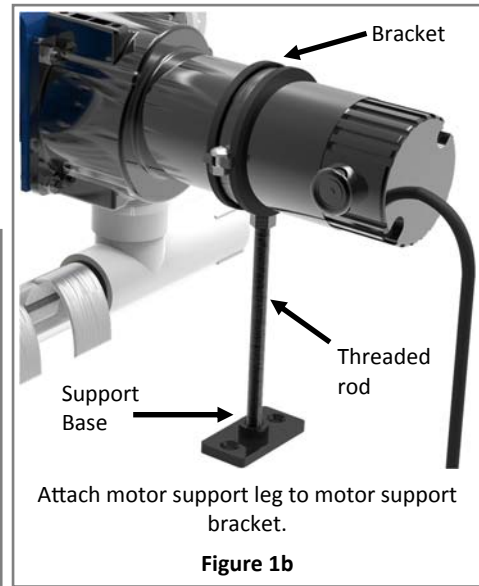
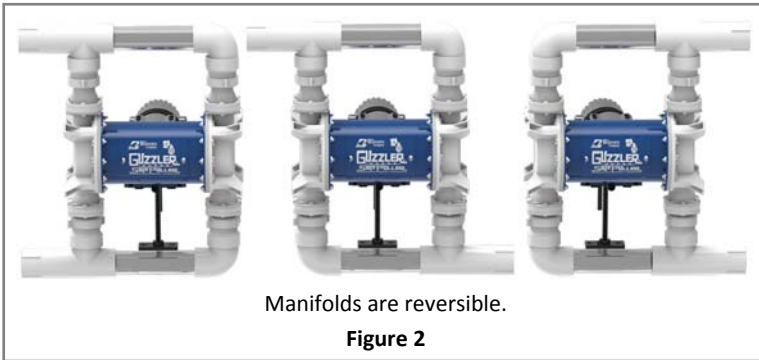
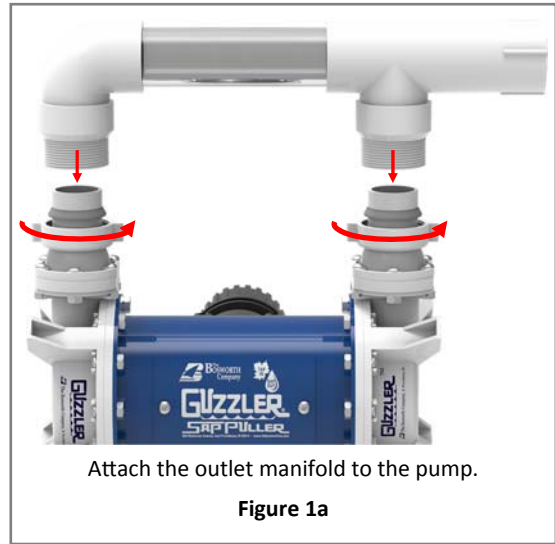

IMPORTANT SAFETY INFORMATION

NEVER OPERATE YOUR GUZZLER G2 SAPPULLER WITHOUT THE PUMP HOUSING COVER PLATE PROPERLY INSTALLED ON THE PUMP.

NEVER REACH INSIDE THE PUMP HOUSING OR INSERT ANY OBJECTS INTO THE PUMP HOUSING WHILE THE PUMP IS OPERATING. SERIOUS INJURY OR DAMAGE TO THE PUMP WILL RESULT.

ALWAYS CONNECT THE PUMP TO A 12 VDC POWER SOURCE USING PROPERLY INSULATED CONNECTORS. OPERATING THE PUMP WITHOUT PROPER ELECTRICAL CONNECTIONS CAN CREATE A SERIOUS RISK OF ELECTRICAL SHOCK.

It is best to install your Guzzler G2 *SapPuller* pump at or above collection tank level to avoid shortening diaphragm life.

Your Guzzler G2 *SapPuller* pump should be securely mounted to a mounting surface prior to operation. The support bracket of the pump has a mounting leg with two holes that accommodate a 1/4 in (6.4 mm) diameter bolt or screw. (Figure 3) The inlet manifold of the pump should be secured to the mounting surface using the two “C”-clamps provided with the pump. (Figure 4)

Your Guzzler G2 *SapPuller* is equipped either with 1-1/4 in (3.2 cm) Female (inside threads) or 1-1/4 in (3.2 cm) Male (outside threads) ports on the inlet and outlet manifolds. Depending on how your pump is configured, you can connect to your sap lines by screwing a 1-1/4 in (3.2 cm) fitting either into or onto the pump manifold ports. We recommend connecting your pump to the mainline with Quick Connect Couplers so that the pump can be easily disconnected from the line.

The pump should be protected from the weather. If it is placed in an enclosure, be sure to allow adequate air-flow around the motor for cooling.

The Guzzler G2 *SapPuller* requires 12 VDC power. Connecting your pump to two 60 amp-hour 12VDC deep-discharge batteries should provide 10-12 hours of pump operation before requiring recharging. (The motor is rated for 14.0 amps at full load.)

The Guzzler G2 *SapPuller* pump is capable of developing 22 in. of Hg vacuum (0.7 bar), but it is a low-cfm (cubic feet of air per minute) pump. This means that even very small leaks can prevent the pump from delivering its rated vacuum. Maintain your tap lines to keep your system tight and address problems that can cause vacuum leaks.

When installing the Guzzler *SapPuller*, we recommend that you install a shut-off valve and a vacuum gauge – in that sequence – “in front of” the pump; i.e., just before your connection to the pump’s inlet manifold. (Figure 5)

If you experience a loss of vacuum in your system – as registered in the gauge near the pump – slowly turn the shut-off valve to isolate the pump from your mainline. **DO NOT SHUT THE VALVE SUDDENLY, AS PUMP DAMAGE MAY RESULT.** If the gauge begins to return to normal operating vacuum, then the pump is working properly and the source of the leak is somewhere in your sap lines or taps. If, on the other hand, the pump fails to recover normal vacuum, then the pump is the source of the problem, and you should inspect the pump diaphragms and/or valves for any holes or tears. In the case of the valves, check for any material that may have entered the pump and lodged in the valve body, preventing the valve from proper opening and closing.

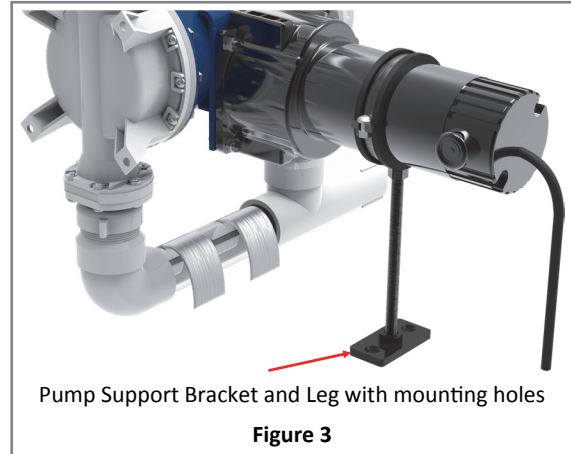

Figure 3

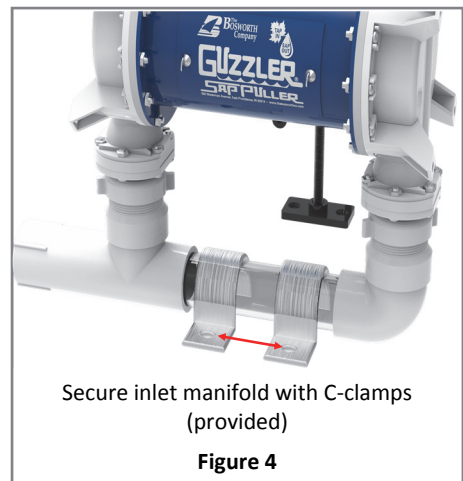

Figure 4

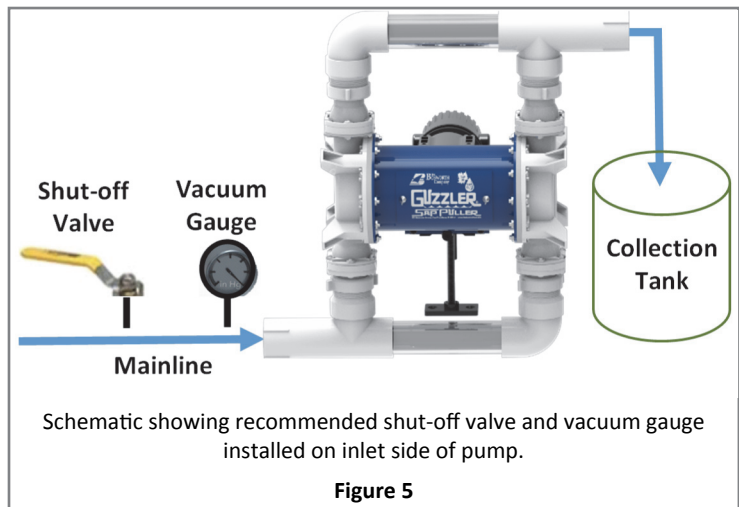

Figure 5

Installation and Operating Information

The motor on your Guzzler G2 *SapPuller* Pump has a maximum service temperature of 104°F (40°C). Ensure that the motor is protected from the elements, but that it also has adequate airflow during operation to prevent overheating.

If there is a risk of freezing conditions, we recommend that you disconnect the pump from your sap lines when the pump is not running and drain any excess sap from the pump. Sap can freeze within the pump bodies or lines. If this happens and the pump is turned on, it will result in damage to various pump components, including pump bodies, valves, diaphragms and manifolds. We recommend flushing the pump (i.e., letting it pull a full volume of water) and then draining it by tipping it over to remove any remaining water from the manifolds to help prevent freezing.

To shut the pump down and disconnect it from the mainline, first turn the pump off. Then, close the shut-off valve to isolate and maintain some vacuum in the mainline. Then disconnect the pump from the mainline, using Quick Couplers if you have used these for your pump-to-mainline connection. Turn the pump back on briefly to flush any remaining sap from it. Finally, tilt the pump to drain out any remaining sap from the manifolds.

Over time, the elastomer components of the pump (i.e., the diaphragms and valves) will fail. Diaphragms tend to develop a hole or tear. If that happens to one of the diaphragms in your twin diaphragm pump, the pump will continue to develop vacuum as a result of the action of the remaining functional diaphragm, but the flow of sap through the pump will be reduced by half of its normal volume. It will be apparent when a diaphragm fails, because sap will leak from the diaphragm into the housing of the pump, draining out through either of the two drain holes at the bottom of the pump housing. Your Guzzler G2 pump ships with two spare diaphragms. Directions for changing a diaphragm are provided on page 6.

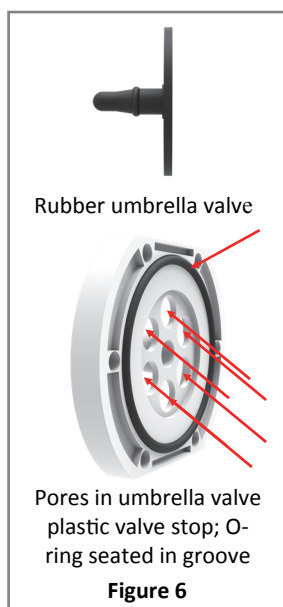

The design of the umbrella valves in your Guzzler G2 *SapPuller* pump features a rubber valve with a flat round disk held under tension against a plastic plate (the “valve stop”) that contains a number of holes or “pores”. (Figure 6) When pressure is applied to one side of the valve stop, it pushes the rubber disk away from the holes, like an umbrella turning inside out. (Figure 7) When this happens, fluid or air can pass through the holes. When the pressure is reversed, the rubber disk is forced against the holes, making a tight seal and preventing any fluid or air from passing.

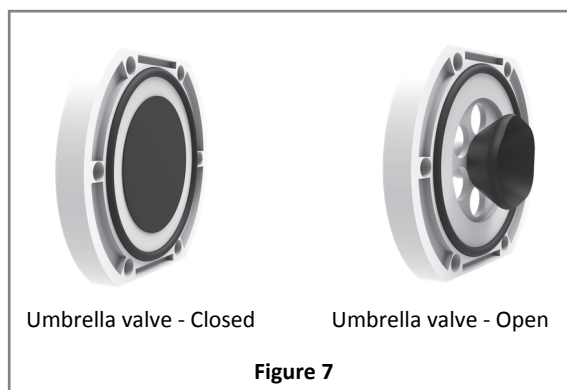

If there is material (e.g., wood shavings from taps, plastic shavings from tubing, etc.) in the sap flowing through the pump, this material may become lodged in the valve pores, preventing the rubber umbrella valve from sealing tightly against the valve stop. When this happens, the diaphragm working these valves will be unable to develop any vacuum. The result will be the same as if the diaphragm had developed a hole or tear; namely, the flow rate of the Guzzler G2 *SapPuller* will be reduced by half, but this valve malfunction will not result in any leaking of sap into the pump housing. To correct the problem the valve should be removed, inspected and cleaned. Several of the steps involved in doing this are the same as the steps required to change a valve. (Instructions on changing valves are provided below.)

Changing the Diaphragm and Valves (Optional)

When replacing the diaphragm it is best to remove and repair only one pump body before attempting to remove the other body. Close attention should be paid to the orientation of various parts. The use of witness marks may be helpful during the reassembly.

Removing the old Diaphragm; Quick Valve Change

1. Disconnect the power.
2. Place the pump assembly with the motor in a vertical position.
3. Remove the manifolds by loosening the hose clamps holding the manifold to the pump flanges.
4. Remove the 10 screws holding the pump body to the housing. (Figure 8)
5. Remove the pump body to expose the diaphragm screw attaching the plastic “button” (a plastic support plate) to the diaphragm.
6. Pull the diaphragm out to its maximum travel. Remove the slotted head screw, washer, button and diaphragm from the plastic clevis. (Figure 9)

Note: If you plan to change the valves, do so now. Otherwise, go to step 10.

7. Using a narrow flat-tipped screw driver, push on the stem (center) of the umbrella valve. Continue pushing the valve from the pump. (Figure 10)
8. Push the new umbrella valve (stem end first) toward the flat side of the valve stop. Ensure the valve is seated in the center hole of the valve stop. Using needle-nose pliers, pull on the valve stem from the other side until it snaps securely into place.
9. Repeat steps 7 and 8 to change the other umbrella valve.

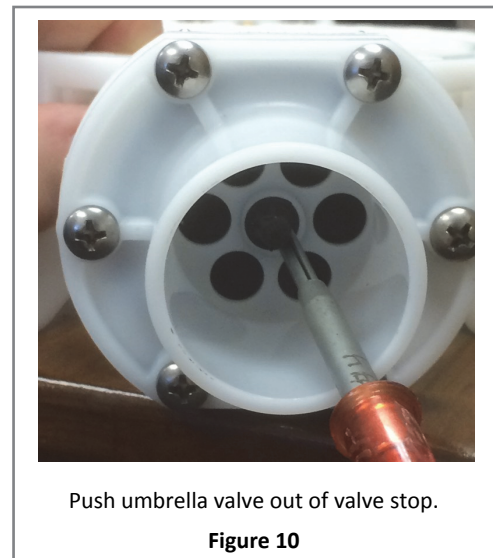

Changing the Diaphragm

Installing a new Diaphragm

10. Place the new diaphragm onto the clevis and secure it with the button (rounded edge side toward diaphragm), washer & screw. Note: Be sure to place the diaphragm on the clevis so that the ridge running along the diaphragm's circumference is facing toward you. (Figure 11) (The other side of the diaphragm's outer edge is flat.) Be sure the screw is tight. We recommend using blue Loctite on the screw to help ensure it does not come loose during pump operation.



11. Place the pump body up against the diaphragm and align it with the holes in the housing. (Figure 12) Be sure that the diaphragm's outer lip sits in the groove running around the circumference of the pump body. (Figure 13) (Note: Ensure the pump body is installed in the correct orientation, with the outlet facing up.)

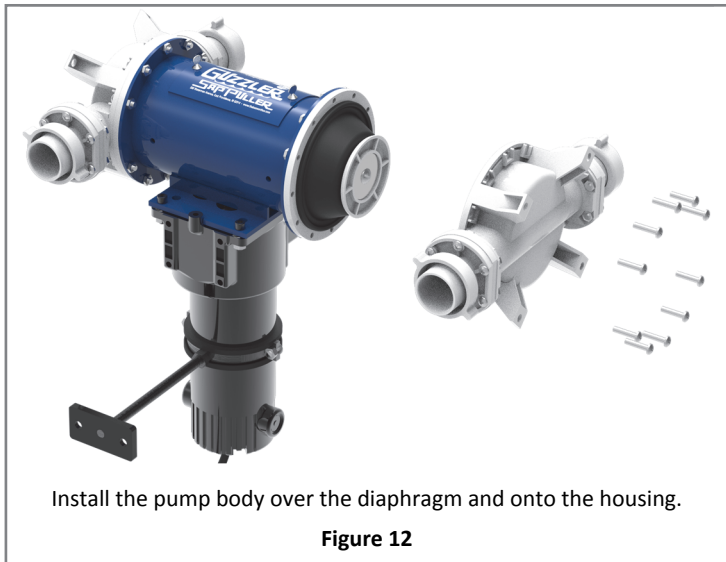

12. Fasten the pump body to the housing using the 10 screws and nuts. Start all screws and nuts before tightening them down. Tighten to a maximum of 30 in-lbs of torque. Tighten screws evenly (crisscross pattern). Do not completely tighten screws until everything is aligned.

13. If necessary, repeat steps 4-12 for the other pump body.

14. Replace the manifolds and tighten all hose clamps.

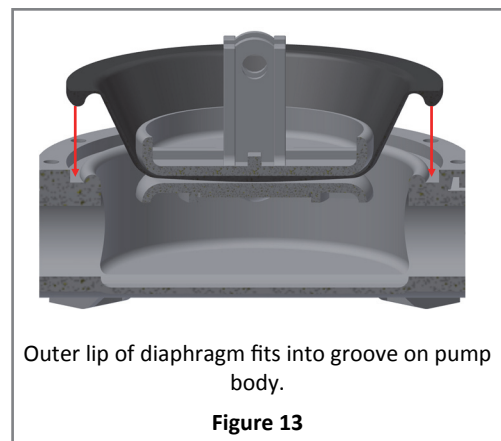

Each pump body in the Guzzler G2 SapPULLER pump features a pair of valves (a total of 4 for the pump). A valve is fastened between the pump body and each of its inlet and outlet ports. (Figure 14)

Valves are typically replaced in pairs; i.e., the inlet and outlet valve of a given pump body are replaced at the same time.

When replacing a pair of pump valves, it is best that only one valve is removed and replaced before attempting to remove and replace the other valve.

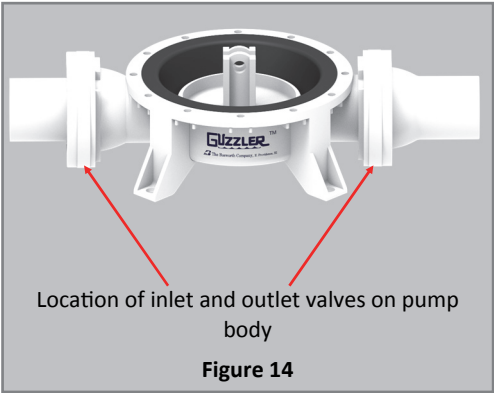

Removing the Valve

1. Disconnect the power.
2. Place the pump assembly with the motor in a vertical position.
3. Remove the inlet manifold by loosening the hose clamps holding the manifold to the pump flanges.

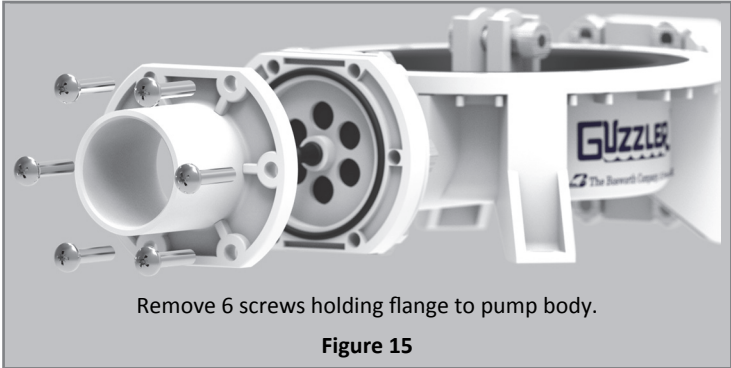

4. Remove the 6 screws holding the inlet flange to the pump body. (Figure 15) The umbrella valve is located between this flange and the pump body.

Note the orientation of the umbrella valve. The valve stem points opposite to the direction of fluid flow. (Figure 16)

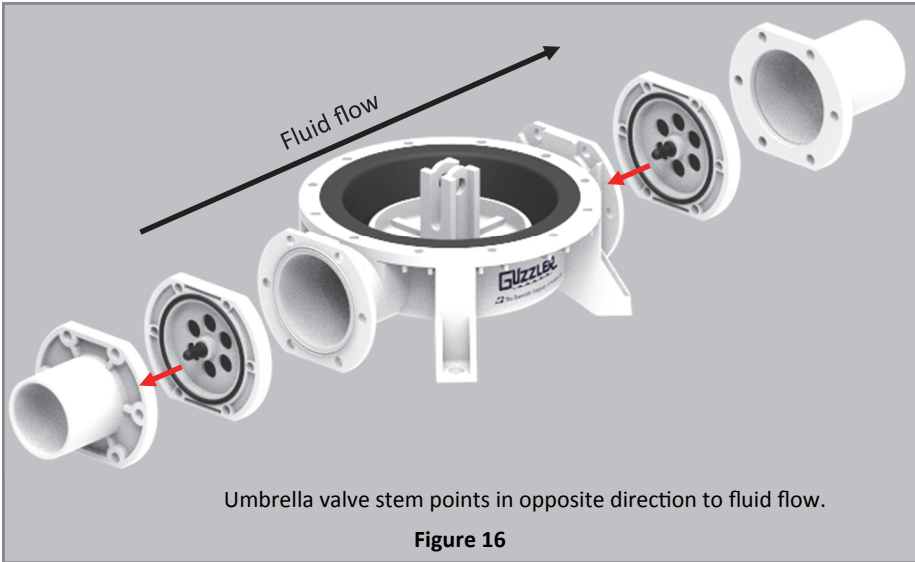

Changing Pump Valves; Replacement Parts

Installing the Valve

5. Inspect the rubber umbrella valve for any tears. Inspect the valve pores and remove any dirt or material that may have become lodged in the pores. Inspect O-rings for any sign of wear and replace as necessary. Ensure that they are correctly installed in the valve stop grooves. (Figure 17)
6. To replace the umbrella valve, use a pair of pliers to grasp the flat portion of the old umbrella valve and pull the entire valve through the valve stop center retaining hole. Insert the stem of the new valve into the valve stop retaining hole so that the flat portion of the valve is on the same side of the valve stop as the old valve. Use pliers to grasp the stem of the valve on the other side and pull it completely through until it snaps into place.
7. Position the new umbrella valve (or the inspected and cleaned old valve) between the pump body and the pump inlet flange, taking care that the flat side of the valve is facing toward the pump body and the O-rings are in place. (Figure 16) Fasten the pump flange and the valve stop to the pump body using the 6 flange screws.
8. Re-install the inlet manifold.
9. Repeat steps 3-8, this time with the outlet side of the pump. However, when installing the umbrella valve **on the pump outlet, be sure that the flat side of the valve faces away from the pump body and toward the outlet flange.**

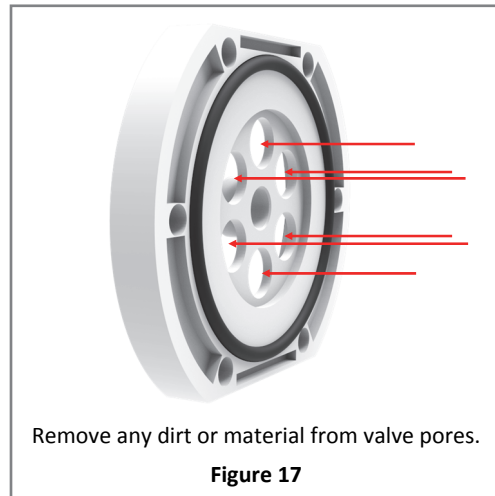

NOTE: IF THE UMBRELLA VALVES ARE NOT ORIENTED CORRECTLY IN THE PUMP FLANGES, THE PUMP WILL NOT FUNCTION PROPERLY AND COULD BE DAMAGED UPON OPERATION.

Replacement Parts

Your Guzzler G2 *SapPuller* pump comes with a pair of replacement diaphragms. Additionally, The Bosworth Company sells a full line of replacement parts for your pump, including replacement diaphragms and valves. You can order replacement parts directly through your distributor or by going on our website at www.thebosworthco.com